

ML 4000

The **ML4000** is the ideal all-purpose solution for install, PA hire and touring applications, handling both front-of-house and stage monitor mixing with ease. With the intuitive layout, and the traditional British EQ and high-definition preamp, getting the right sound couldn't be easier.

ML4000 is a dual function, LCRplus, 8 group, 12 aux, 12x4 matrix, VCA console. Frame sizes range from 24+2 to 48+2 channels, with sidecar expansion to 96+2 channels.



FEATURES

- ▶ 24+2, 32+2, 40+2, 48+2, plus up to 2x 24 input sidecars, total 96+2 channels
- ▶ 2 extra dual input stereo channels fitted as standard
- ▶ B option for 4 extra dual stereos in place of mono channels
- ▶ 8 VCA groups with mute and PAFL functions
- ▶ Dual functionality for mixing front-of-house, stage monitors or both
- ▶ Monitor mode provides 12 auxes with pre switches, faders, inserts, mutes, bus and out meters
- ▶ FOH mode provides 8 groups and 12 auxes
- ▶ LCRplus panning available from channels and groups.
- ▶ Stereo switching for up to 2 true stereo sends from pairs of auxes
- ▶ 12x4 matrix with inserts and external inputs
- ▶ 8 mute groups
- ▶ 4 band, full sweep EQ with switched Q on midrange
- ▶ Swept 20-400Hz HPF
- ▶ Stereos can mix two balanced sources into one channel, includes L, R L+R mono switching
- ▶ Balanced inserts with separate send and return sockets
- ▶ 128 snapshot memories for recall of VCA assignments and mutes via MIDI/RS232
- ▶ **ALLEN & HEATH ML Archiver** software available for PC control of the memories
- ▶ Talkback to any of the fader masters, matrix, LR and C
- ▶ ClearCom™ compatible intercom works with console headphones and TB mic
- ▶ Intelligent PAFL SYSTEM – PFL override AFL for quick multi-mix output/source monitoring
- ▶ Intelligent PAFL system – AFL cancel PFL, all clear, auto-cancel or add modes
- ▶ Intelligent PAFL system – Input PFL or stereo-in-place AFL
- ▶ Intelligent PAFL system – Mono or stereo AFL of masters and matrix
- ▶ Simultaneous LED bar and moving coil VU metering of all main outputs and P/AFL
- ▶ Fader driven engineer's listen wedge feed with insert in monitor mode
- ▶ Separate stereo headphones and local monitor control
- ▶ LCR to stereo engineer's monitor capability
- ▶ 1kHz oscillator / pink noise generator
- ▶ Preamp input capability for mic or line up to +30dBu
- ▶ Main, group, aux and matrix outputs on balanced XLR
- ▶ 4-pin XLR lamp sockets – **ALLEN & HEATH** LEDlamp available
- ▶ Uses external power supply with built-in combiner for redundant backup
- ▶ Internal aux jumper options for pre-insert, pre/post-EQ, pre/post-mute settings



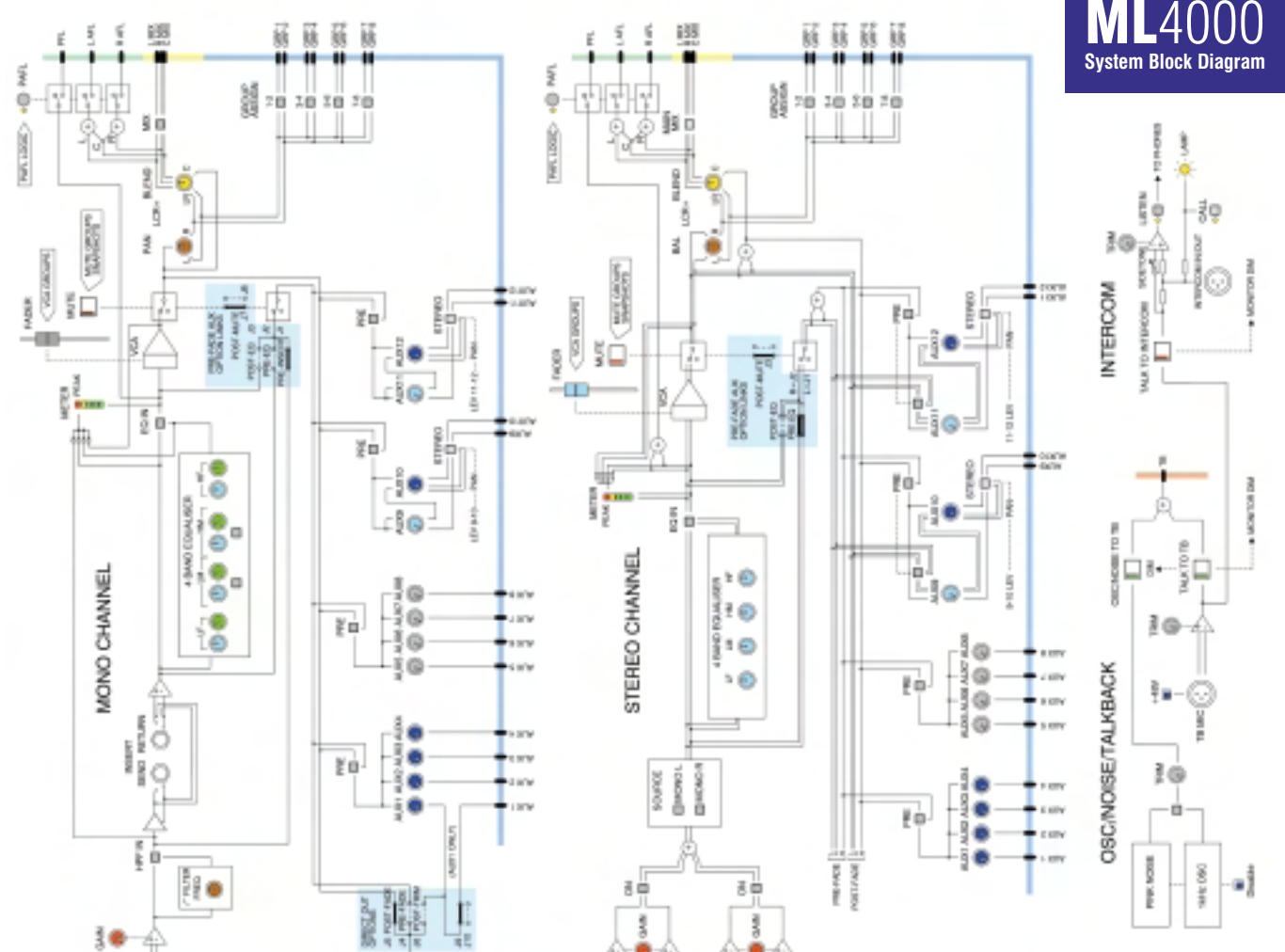
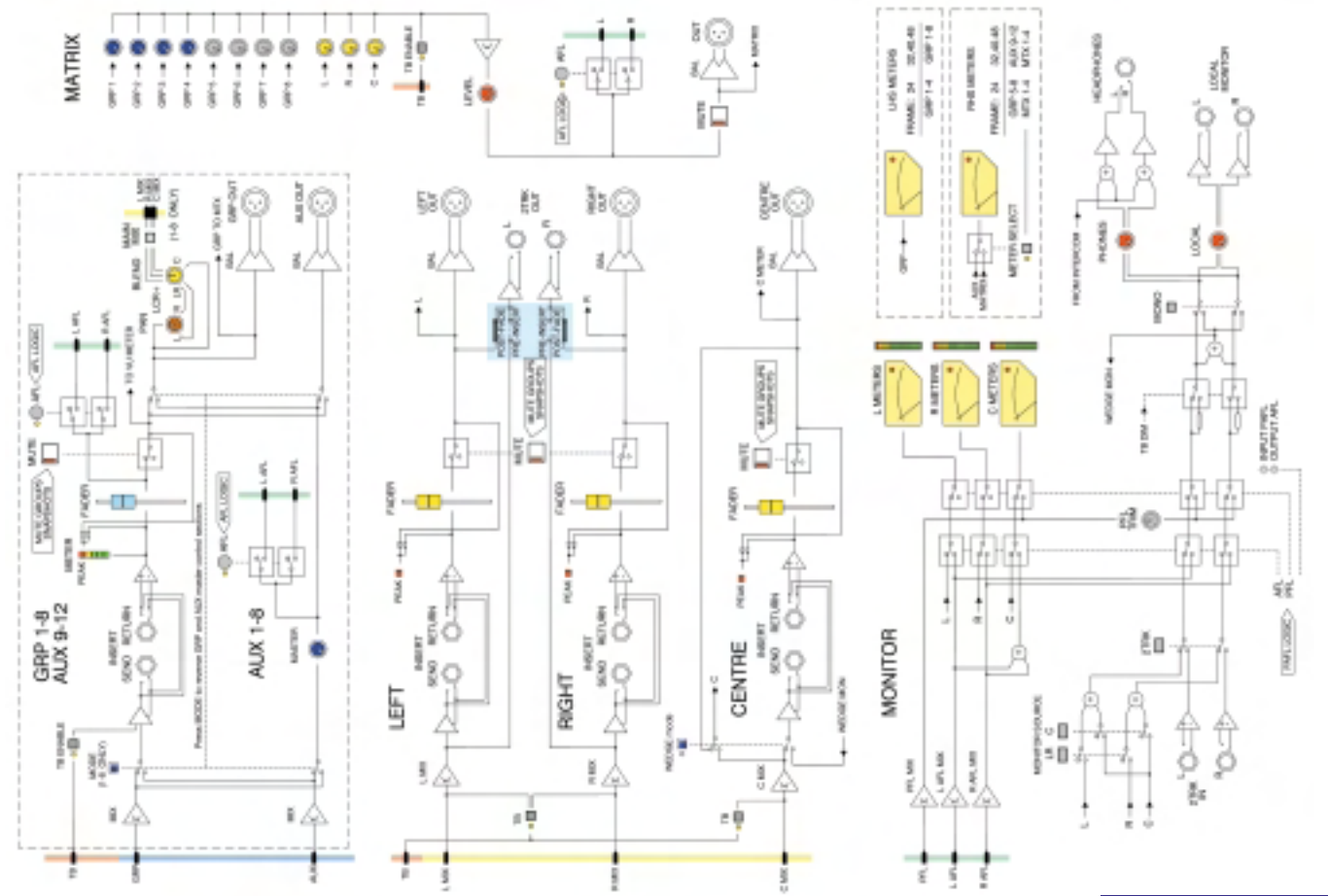

ML4000
System Block Diagram