

FRX+940/FRX+940PI

15-Inch Two-Way
Horn-Loaded 90° x 40°
Coaxial Speaker System



Key Features:

- Pattern Control to 500 Hz
- 90° x 40° coverage
- Built-in L-track rigging
- Available in black, white and unfinished
- Passive or bi-amp operation
- High sensitivity, 104 dB
- Ring-Mode Decoupling / RMD™
- Full Coaxial Design
- Weatherized Version Available (FRX+940PI)



General Description:

FRX+ series is designed for applications in highly reverberant spaces where excellent directivity control down to 500 Hz is critical. In a trapezoidal enclosure no taller than a typical compact system and only a bit wider, they maintain control of coverage angles down to 500 Hz. A 15" LF transducer is coaxially horn loaded with a mouth nearly the size of the enclosure to provide excellent LF pattern control. These professional fixed install speakers deliver a broad range of performance options including multiple rotatable horn patterns, matching sub-woofer, easily switchable passive or bi-amp operation, and EV's world renowned transducer technology for response that is smooth and linear. The FRX+ is an economical and flexible solution for the most demanding installations.

Same size full-range and sub-woofer systems allow the installer to construct arrays covering the most demanding acoustical environments while maintaining an aesthetic and uniform installation. The structural integrity of the FRX+ cabinets allows for vertical arrays up to 2 boxes in height. All FRX+ systems are available in black or white EVCoat™, and unfinished. The PI version includes stainless steel hardware and a multilayer stainless steel grille that protects against rain, sprayed water, and dust to IEC 529 IP 44 Mil Spec 810 humidity, salt spray, and UV specifications. External components and fasteners are aluminum and stainless steel. Performance may be further enhanced by bi-amping with the Electro-Voice Dx-38 Digital Sound System Processor. A 300W line transformer is available as a contractor installed item.

Technical Specifications:

Freq. Response ¹ (-3 dB):	60Hz-15kHz
Freq. Range ¹ (-10 dB):	52Hz-16kHz
Max Calculated SPL:	133 dB
Horizontal Coverage:	90°
Vertical Coverage:	40°
LF Power Handling:	400W Continuous, 1600W Peak
HF Power Handling:	60W Continuous, 240W Peak
Passive Power Handling:	400W Continuous, 1600W Peak
LF Sensitivity (Bi-Amp):	104 dB, 1W/1m
HF Sensitivity (Bi-Amp):	109 dB, 1W/1m
Passive System Sensitivity:	104 dB, 1W/1m
Impedance:	8 ohms (Nominal), 7.2 ohms (Min.)
LF Transducer:	DL15X 15" (381mm) Driver, 8 ohms
HF Transducer:	DH2t 2" (51mm) Diaphragm Comp. Driver, 8 ohms
Passive Crossover Frequency:	1350 Hz
Connectors:	Two barrier strips
Enclosure Material:	13-ply Birch plywood
Grille:	16 GA steel (PI Version Stainless Steel)
Environmental Spec:	IEC 529 IP24, (PI Version IP44) MIL STD 810
Transformer:	See Page 4
Dim (H x W x D):	31.5" x 28.5" x 27.0" (800 x 724 x 686 mm)
Net Weight (each):	152 lbs (69.0 kg)
Shipping Weight:	157 lbs (71.2 kg)

¹ Full Space measurement. Half Space use will improve LF response.

FRX+940/FRX+940PI Full Range Loudspeaker

Frequency Response (Full Space):

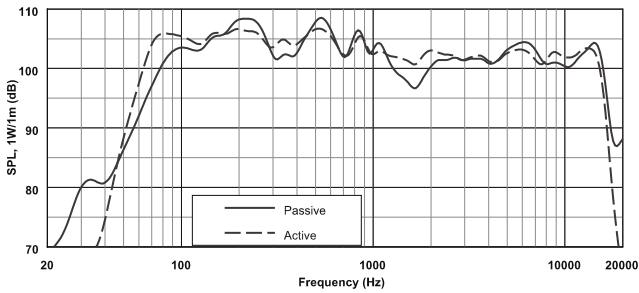

Impedance:

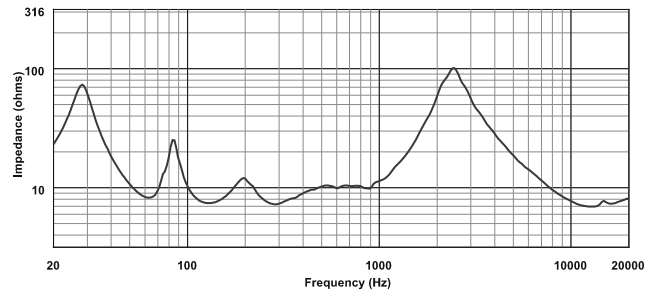

Beamwidth:

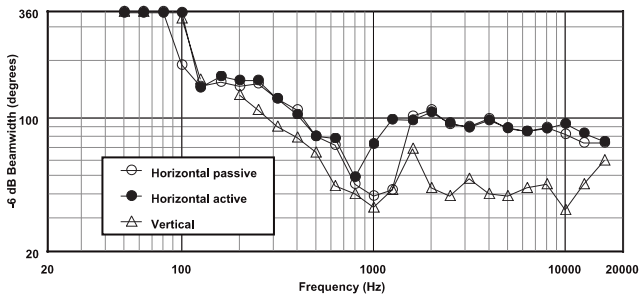

Horizontal Off Axis Frequency Response:

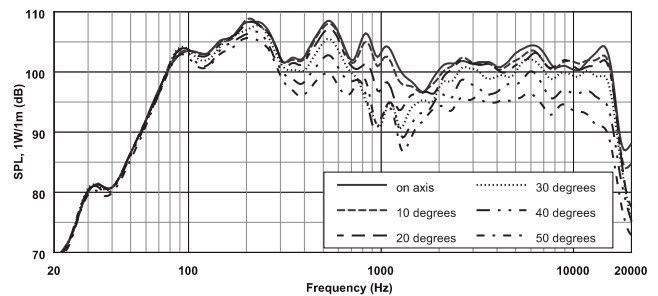

Directivity:

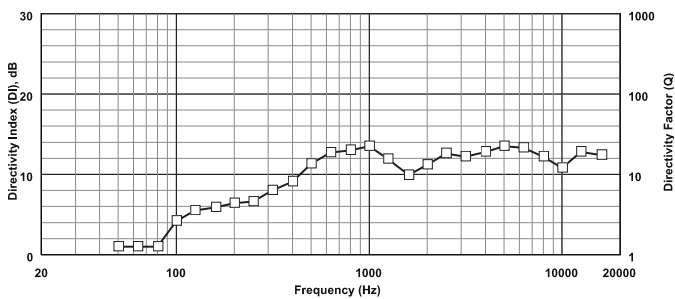

Vertical Off Axis Frequency Response (up/down):

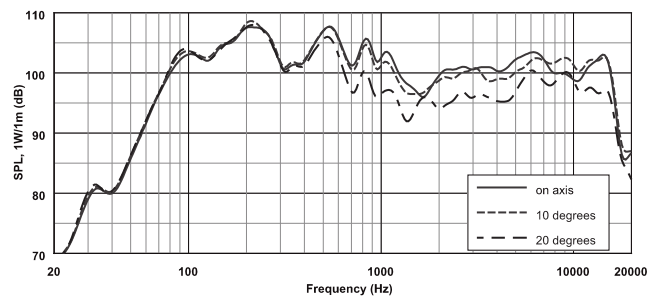

Block Diagram:

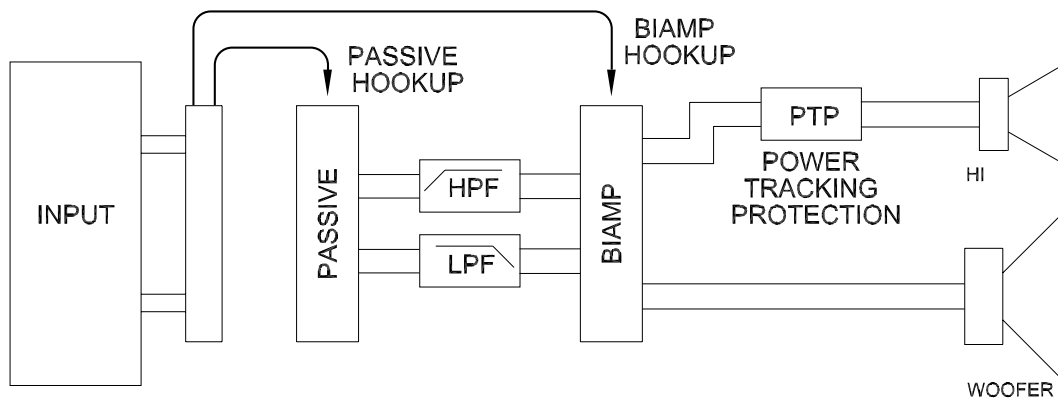

Horizontal 1/3 Octave Polars:

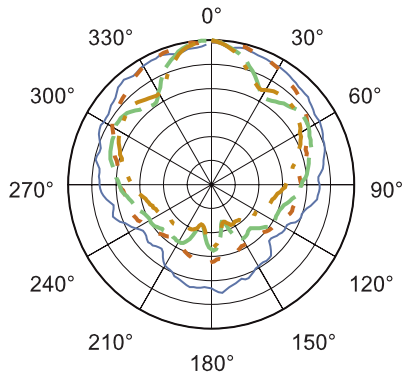

- 200 Hz
- - - 400 Hz
- - - 800 Hz
- · - 1000 Hz

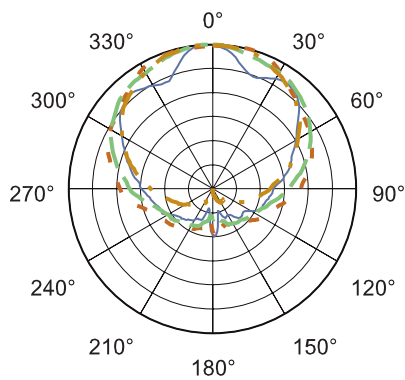

- 1250 Hz
- - - 1600 Hz
- - - 2000 Hz
- · - 2500 Hz

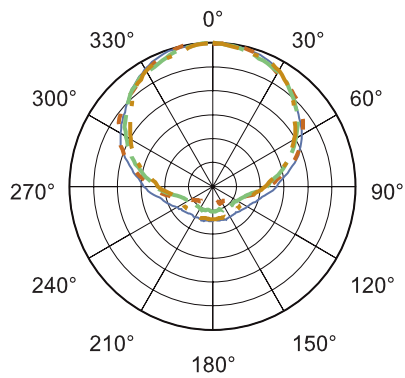

- 3150 Hz
- - - 4000 Hz
- - - 5000 Hz
- · - 6300 Hz

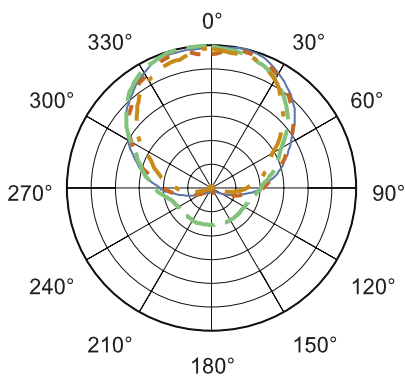

- 8000 Hz
- - - 10000 Hz
- - - 12500 Hz
- · - 16000 Hz

Graph scales are 6 dB per division

Vertical 1/3 Octave Polars:

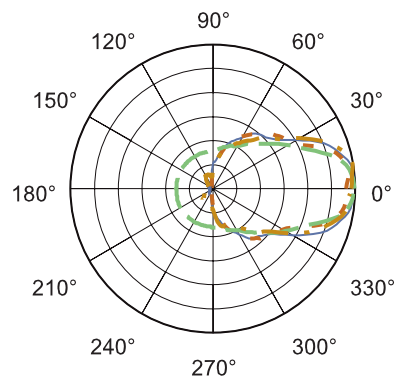
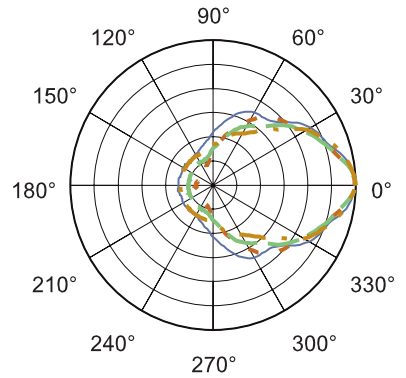
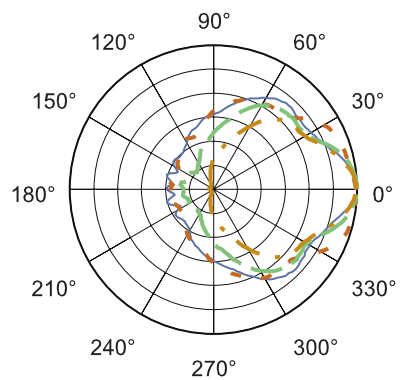
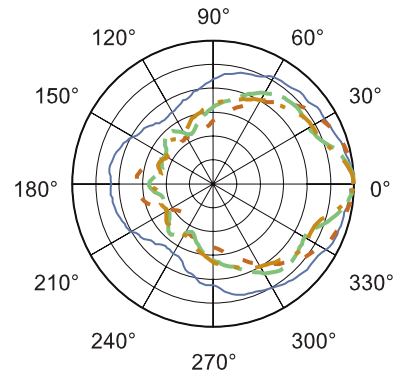

Dimension Drawings:

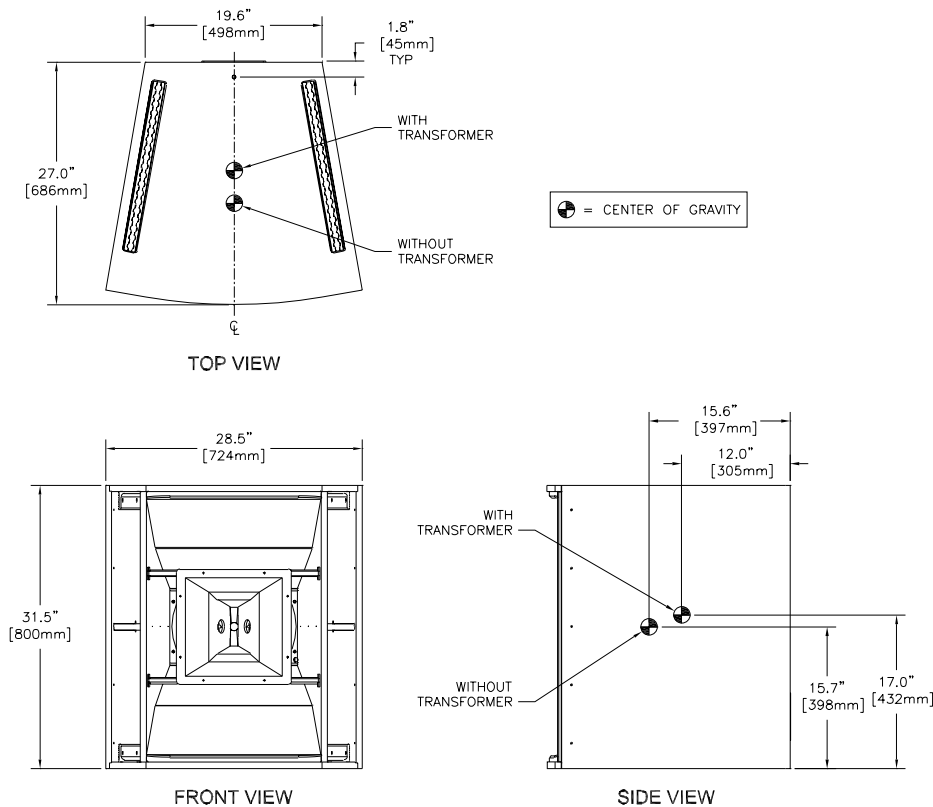

Line Transformer Kit:

Part number 301401-000 transformer kit is available to mount internally to any FRX+ System. The kit includes a special 300 Watt line transformer for operating on 70, 100, and 140 volt distributed line systems, wiring harness, instructions, and hardware. At 300 Watts it has a bandwidth of 35 Hz to 15 kHz ± 1 dB.

FRX+940 Part Numbers

- 301238-000 - Unfinished
- 301238-001 - Black
- 301238-002 - White

FRX+940PI Part Numbers

- 301393-001 - Black

Architectural & Engineering Specs:

The loudspeaker system shall be a coaxial, two-way full range design consisting of a 15-inch woofer, a high-frequency compression driver on a molded constant-directivity horn and a dividing network providing an acoustic crossover frequency of 1,350 Hz. The system shall be configurable in a biamp mode by moving a single connector in the crossover network. The loudspeaker shall meet the following performance criteria; power-handling, 400 watts, based upon ANSI/EIA RS-426-A 1980 standard for full-range loudspeaker systems; frequency response, smooth and usable at high SPL levels from 60 Hz to 15 kHz; pressure sensitivity, 104 dB SPL (passive mode) or 105 dB (LF)/109 dB (HF) in biamp mode for 1W at 1m; impedance, 8 ohms nominal, 7 ohms minimum. The system shall have a distribution pattern of 90° nominal horizontally from 500 Hz to 15 kHz and 40° nominal vertically from 500 Hz to 15 kHz. The enclosure shall be constructed from 13-ply birch plywood and braced appropriately, and the grille shall be constructed from 16 GA powder-coated steel backed by acoustically transparent fabric. The PI version shall have multilayer stainless steel grille, stainless steel fasteners, and aluminum hardware. The dimensions shall be 800 mm (31.5 in.) high by 724 mm (28.5 in.) wide by 686 mm (27.0 in.) deep. Net weight shall be 68.95 kg (152 lb).

The two-way loudspeaker shall be the Electro-Voice FRX+940 or FRX+940PI.



12000 Portland Avenue South, Burnsville, MN 55337
Phone: 952/884-4051, Fax: 952/884-0043

www.electrovoice.com

© Telex Communications, Inc. 6/2007

Part Number 38110-124 Rev. H

U.S.A. and Canada only. For customer orders, contact Customer Service at:
800/392-3497 Fax: 800/955-6831

Europe, Africa, and Middle East only. For customer orders, contact Customer Service at:
+ 49 9421-706 0 Fax: + 49 9421-706 265

Other International locations. For customer orders, contact Customer Service at:
+ 1 952 884-4051 Fax: + 1 952 736-4212

For warranty repair or service information, contact the Service Repair department at:
800/685-2606

For technical assistance, contact Technical Support at: **866/78AUDIO**

Specifications subject to change without notice.