



SLIMLINE® ELECTROL®

Automatic Electric Projection Screen Model

SPECIFICATION DATA

DA-LITE SCREEN COMPANY, INC.
 3100 North Detroit Street
 Post Office Box 137
 Warsaw, Indiana 46581-0137
 Phone: 574-267-8101
 800-622-3737
 Fax: 574-267-7804
 Toll Free Fax: 877-325-4832
 www.da-lite.com
 e-mail: info@da-lite.com

SUGGESTED SPECIFICATIONS: _____ projection screen(s), _____ (H) x _____ (W), electrically operated 120 volt (60 HZ) not more than 1.2 amp. Shall have specially designed motor mounted inside the roller to be three wire with ground quick reversal type, oiled for life, with automatic thermal overload cut-out, integral gears, capacitor and an electric brake to prevent coasting. To have preset but adjustable limit switches to automatically stop picture surface in the "up" and "down" positions. The roller to be of rigid metal. Screen fabric to be flame retardant and mildew resistant fiberglass with black masking borders. Bottom of fabric shall be formed into a pocket holding a metal rod. Ends of the slat shall be protected by plastic outer caps. Case to be powder coated white 22 gauge steel, 2³/₄" in width, octagon in shape with flat back design. Case with sturdy brackets for wall or ceiling installation. To be complete with control cable with operating switch built into line and power cable (2 wire plus ground) from switch to 3-prong plug. Screen to be listed by Underwriters' Laboratories.

All viewing surfaces will be seamless.



VIDEO (NTSC 4:3) FORMAT DIMENSIONS (2" standard black drop at top)

Viewing Area		Nominal Diagonal		A - Overall Length of Case		B - Between Hanger Eyes		Approx. Ship. Wt.	
H x W	Cm	In.	Cm	In.	Cm	In.	Cm	Lbs.	Kg
43" x 57"	109 x 145	72"	183	67 ¹ / ₈ "	171	66 ³ / ₈ "	169	22	10.0
50" x 67"	127 x 170	84"	213	77 ¹ / ₈ "	196	76 ³ / ₈ "	194	24	10.9
60" x 80"	152 x 203	100"	254	91 ¹ / ₈ "	231	90 ³ / ₈ "	230	26	11.8

HDTV (16:9) FORMAT DIMENSIONS (2" standard black drop at top)

Viewing Area		Nominal Diagonal		A - Overall Length of Case		B - Between Hanger Eyes		Approx. Ship. Wt.	
H x W	Cm	In.	Cm	In.	Cm	In.	Cm	Lbs.	Kg
45" x 80"	114 x 203	92"	234	91 ¹ / ₈ "	231	90 ³ / ₈ "	230	26	11.8

SQUARE FORMAT DIMENSIONS

Sizes		A - Overall Length of Case		B - Between Hanger Eyes		Approx. Ship. Wt.	
H x W	Cm	In.	Cm	In.	Cm	Lbs.	Kg
60" x 60"	152 x 152	67 ¹ / ₈ "	171	66 ³ / ₈ "	169	22	10.0
70" x 70"	178 x 178	77 ¹ / ₈ "	196	76 ³ / ₈ "	194	24	10.9

Specifications are subject to change without notice.

SUGGESTED METHODS OF INSTALLATION

WALL MOUNTING
Slip hanger eyes over screws well secured in wall.

PICTURE SURFACE

CEILING MOUNTING
Place "D" Rings over hooks well secured in ceiling.

PICTURE SURFACE

WALL BRACKET MOUNTING
Use No. 6 brackets to hang behind beam or valance.

PICTURE SURFACE

CONCEALED
Allow room for access.

PICTURE SURFACE

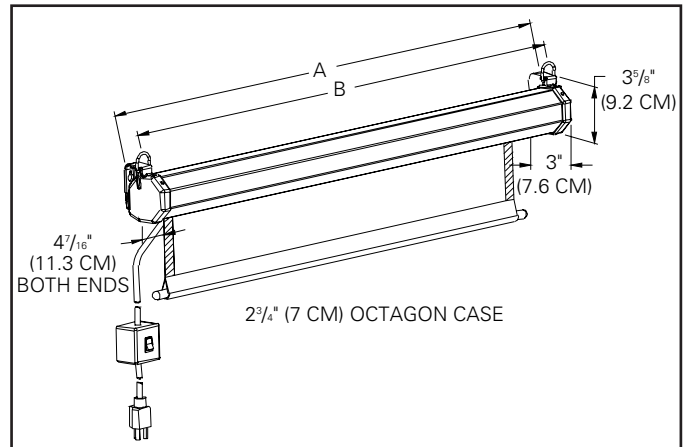

PLEASE MARK APPROPRIATE SELECTIONS:

Select size from chart above

Select viewing surface:

- Matte White High Power®
 Greenguard® and Greenguard® Children and Schools Certified.

Options:

- No. 6 Non-adjustable Extension Brackets (75# per pair maximum) (black or white).
 No. 11 Non-adjustable Extension Brackets (75# per pair maximum) (black or white).
 220V (50 HZ Motor).
 No Borders (Black Masking Borders standard).
 Black case (white standard).

Project: _____

Architect: _____

Phone: _____

Contractor: _____

Phone: _____

Supervisor: _____

Phone: _____

Date: _____

Revised: _____