

The
POWER *In*
PRESENTATION PRODUCTS

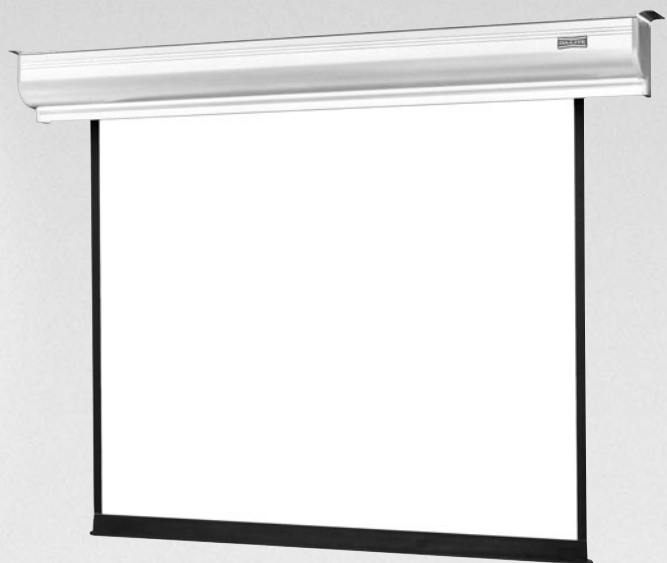

Instruction Book for
CONTOUR[®] ELECTROL[®]



DA-LITE SCREEN COMPANY, INC.

3100 North Detroit Street
Post Office Box 137
Warsaw, Indiana 46581-0137
Phone: 574-267-8101
800-622-3737
Fax: 574-267-7804
Toll Free Fax: 877-325-4832
www.da-lite.com
e-mail: info@da-lite.com

IMPORTANT SAFETY INSTRUCTIONS

When using your video equipment, basic safety precautions should always be followed, including the following:

1. Read and understand all instructions before using.
2. Position the cord so that it will not be tripped over, pulled, or contact hot surfaces.
3. If an extension cord is necessary, a cord with a current rating at least equal to that of the appliance should be used. Cords rated for less amperage than the appliance may overheat.
4. To reduce the risk of electric shock, do not disassemble this appliance. Contact an authorized service dealer when repair work is required. Incorrect reassembly can cause electric shock when the appliance is used subsequently.
5. The use of an accessory attachment not recommended by the manufacturer may cause a risk of fire, electric shock, or injury to persons.

SAVE THESE INSTRUCTIONS

INSTALLATION

Carefully unpack screen and remove outer wrapping from case.

Remove the black tape and rubber bands from the slat bar after the case has been installed.

There are three ways to install the Contour® Electrol®: Wall Mount, Ceiling Mount, or Ceiling Hook. Procedures for each method are as follows:

Wall Mount

1. Secure the wall mount bracket to the wall at the desired height. Bracket should be fastened to wall studs or some reinforcement within the wall. Concrete or brick walls require special fasteners and anchors.
2. Make sure the bracket is level. See figure 1 for reference dimensions.
3. Keep in mind you will need at least 2-3/8" between the ceiling and the top of the wall mount bracket to be able to position the case on the bracket.
4. Mount the screen case on the wall bracket as shown in figure 1. Be sure the case is fully seated on the bracket. Tighten the stop screws against the wall bracket.

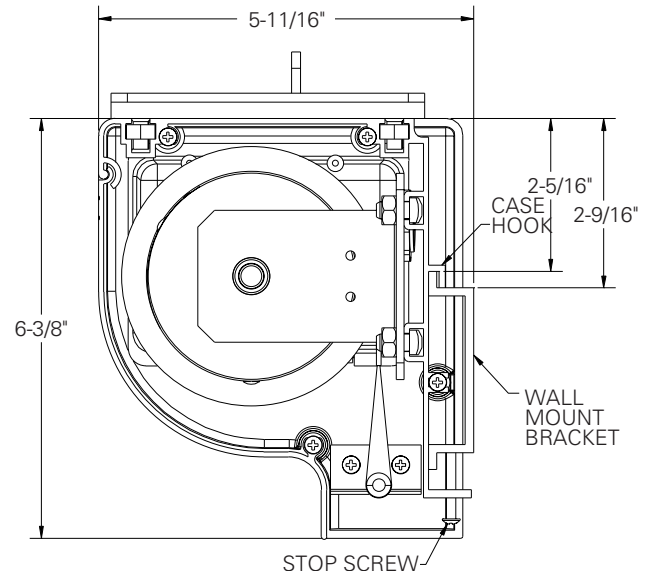

FIGURE 1

Ceiling Mount

1. Do not remove the wall mount bracket, even if you are not using it for mounting. This provides structural stability to the case.
2. Be sure the ceiling has adequate reinforcement to attach the screen brackets.
3. The top of the screen case has two channels with threaded nuts that slide the length of the case. Attach two ceiling mount brackets to the screen case as shown in figure 2. Mount cannot be more than 12" from end of case.
4. Hold the screen case up to the ceiling and mark the hole locations. The brackets have a set of front holes and a set of rear holes. It is best to use at least one hole in each set.

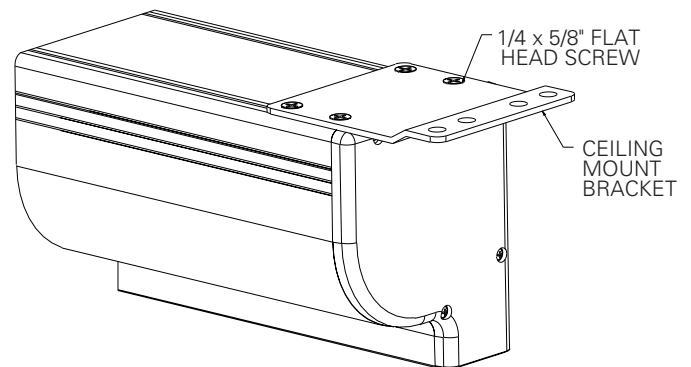

FIGURE 2

Ceiling Hook

1. Do not remove the wall mount bracket, even if you are not using it for mounting. This provides structural stability to the case.
2. Be sure the ceiling has adequate reinforcement to attach a hook anchor.
3. The top of the screen case has two channels with threaded nuts that slide the length of the case. Attach ceiling hook brackets as provided to the screen case as shown in figure 3.
4. The brackets can be attached anywhere within 12" of the end of the case.
5. Attach an S-hook or similar fastener to the hole in the bracket.

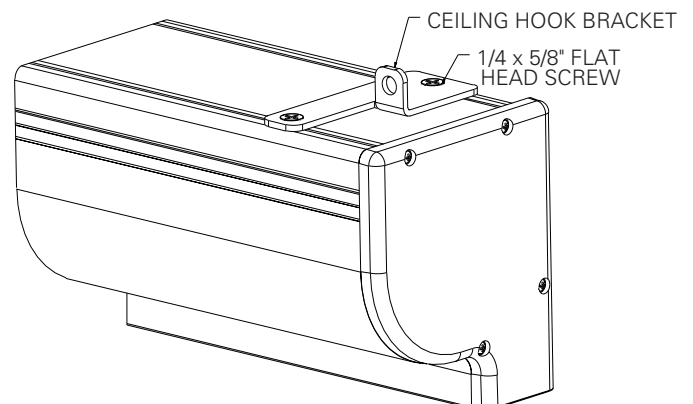

FIGURE 3

ELECTRICAL INSTALLATION

Internal wiring has been completed at the factory. Installer must route power to the wall switch and to the junction box located on the left end of the screen case.

Standard installation is for a single 120VAC or 240VAC wall switch to control the screen. Optional Control units may have been ordered. Wiring diagrams for the built-in VPI and low voltage control are included in these instructions. Refer to additional instructions for the external VPI, external low voltage control, SCB-100 and SCB-200. Refer to the appropriate wiring diagram for your screen.

Test installation by running screen up and down a few times. Be prepared to stop screen. Standard Duty Cycle: 1MIN. ON / 3 MIN. OFF.

NOTE: Must be installed in accordance with the requirements of the Local Building Codes, the Canadian Electrical Code (CEC), CAN/CSA C22.1 and the National Electric Code (NEC), NFPA 70.

SCREEN ADJUSTMENT FOR 120V SCREENS WITHOUT BUILT-IN LOW VOLTAGE CONTROL

Screen travel is stopped automatically in the down and up positions by the limit switches that are preset at the factory. If it's necessary to adjust for more or less drop follow the steps below. The case cover must be removed to access the motor limit switches.

Remove the case cover screw from both ends of the screen. See figures 4 and 5. Be sure to hold the cover while removing the screws.

Rotate the cover up and away from the case until it can be removed.

SETTING THE DOWN LIMIT POSITION

TO REDUCE SCREEN DROP:

Turn the white limit switch screw clockwise to decrease the amount of screen drop. Run the screen down to test the stop position. If the screen drops too far, raise the screen about one foot and adjust the limit switch again. Repeat until the desired position is set.

TO INCREASE SCREEN DROP:

Turn the white limit switch screw counterclockwise to increase the amount of screen drop. Run the screen down to test the stop position. If the screen does not drop enough, raise the screen about one foot and adjust the limit switch again. Repeat until the desired position is set.

CAUTION: Do not adjust for more drop than what was ordered. At least 1-1/2 wraps of fabric must remain on the roller. This screen comes standard with 0" or 2" black at the top. See the specification data sheet for details.

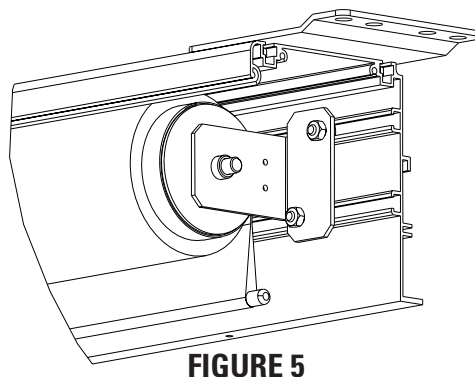
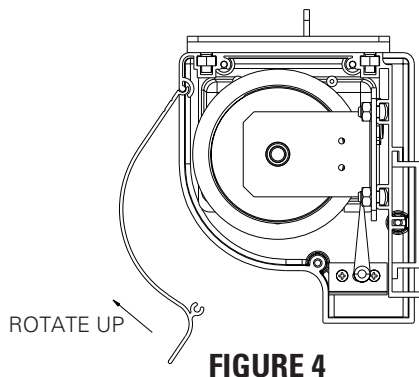

SCREEN ADJUSTMENT FOR 220/240V SCREENS WITHOUT BUILT-IN LOW VOLTAGE CONTROL

Screen travel is stopped automatically in the down and up positions by the limit switches that are preset at the factory. If it's necessary to adjust for more or less drop follow the steps below. The case cover must be removed to access the motor limit switches.

Remove the case cover screw from both ends of the screen. See figures 4 and 5. Be sure to hold the cover while removing the screws.

Rotate the cover up and away from the case until it can be removed.

SETTING THE DOWN LIMIT POSITION

TO REDUCE SCREEN DROP:

Turn the white limit switch screw clockwise to decrease the amount of screen drop. Run the screen down to test the stop position. If the screen drops too far, raise the screen about one foot and adjust the limit switch again. Repeat until the desired position is set.

TO INCREASE SCREEN DROP:

Turn the white limit switch screw counterclockwise to increase the amount of screen drop. Run the screen down to test the stop position. If the screen does not drop enough, raise the screen about one foot and adjust the limit switch again. Repeat until the desired position is set.



CAUTION: Do not adjust for more drop than what was ordered. At least 1-1/2 wraps of fabric must remain on the roller. This screen comes standard with 0" or 2" black at the top. See the specification data sheet for details.

SCREEN ADJUSTMENT FOR SCREENS WITH A BUILT-IN LOW VOLTAGE CONTROL

1. Remove the cover plate from the 3-button wall switch and remove the switch from the junction box.
2. Locate small 3-position switch on back of wall switch. See Figure 10 for 120V screens or Figure 11 for 220/240V screens.



CAUTION: Do not adjust for more drop than what was ordered. At least 1-1/2 wraps of fabric must remain on the roller. This screen comes standard with 0" or 2" black at the top. See the specification data sheet for details.

3. To adjust the down limit switch, slide the 3-position switch to the down position. Press and hold the down button to run the screen down to the desired stop position. Release the button to stop the screen. **DO NOT PUSH THE STOP BUTTON.**
4. When the screen is in the desired down position, slide the 3-position switch to the off (center) position. The down limit switch is now set.
5. To adjust the up limit switch, slide the 3-position switch to the up position. Press and hold the up button to run the screen up to the desired stop position. Release the button to stop the screen. **DO NOT PUSH THE STOP BUTTON.**
6. When the screen is in the desired up position, slide the 3-position switch to the off (center) position. The up limit switch is now set.
7. To test limit switch setting, make sure the 3-position switch is in the off (center) position. Press and release the up or down button on the wall switch to operate the screen.
8. Replace switch and cover plate on the wall.

NOTE: If stop button is pressed, the wall switch will reverse direction. To correct this, press the stop button again. This will reset the switch. You will have to re-set both the up and the down settings.

IMPORTANT NOTE: The wall switch is **REQUIRED** to make any limit switch adjustments, **EVEN** if a third party control system is used. Therefore, it is advised to wire the switch or provide a 4-conductor connection that is accessible.

120V WIRING DIAGRAM FOR STANDARD WALL SWITCH

FIGURE 6

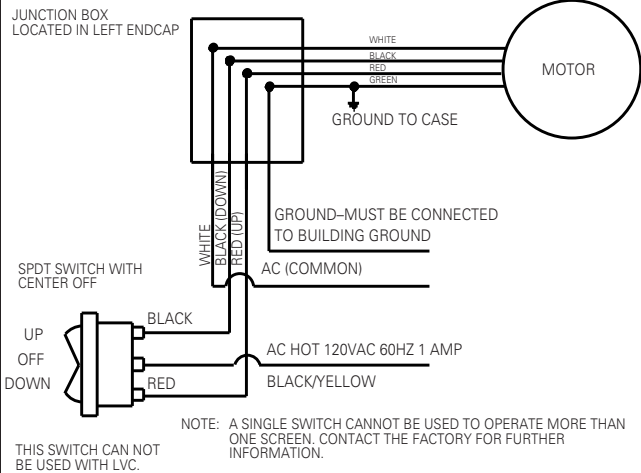

240V WIRING DIAGRAM FOR STANDARD WALL SWITCH

FIGURE 7

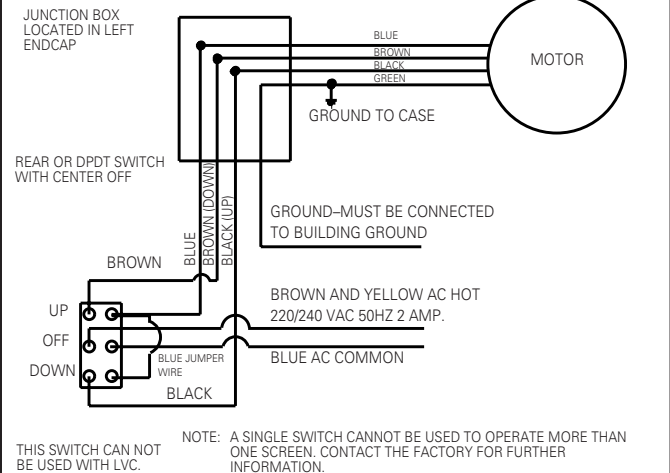

120V WIRING DIAGRAM WITH OPTIONAL BUILT-IN VIDEO PROJECTOR INTERFACE

FIGURE 8

CAUTION: THE PROJECTOR MUST BE TURNED OFF BEFORE CONNECTING THE TRIGGER WIRES TO THE PROJECTOR. FAILURE TO DO SO MAY DAMAGE THE CONTROLLER.

1. Use 2-conductor 20-24 gauge wire to extend the low voltage connection from the projector's 5 or 12-volt screen trigger output to the length required to reach the VPI. When extending the low voltage connection from the projector's screen trigger output, be sure to maintain the proper polarity. The red wire from the VPI is the "signal" and the black wire from the VPI is the "ground".
2. Connect the wires from the VPI that are labeled "Low Voltage Connection" to the end of the extended screen trigger wires above.
3. The wall switch must be placed in the "up" position for the screen to be triggered by the projector.
4. If a wall switch is not being used, please do the following. For 120V units, the black/yellow lead and the red lead for the wall switch must be connected to each other and the black lead must be capped. For 240V units, the black/yellow lead and the black lead for the wall switch must be connected to each other and the brown lead must be capped.

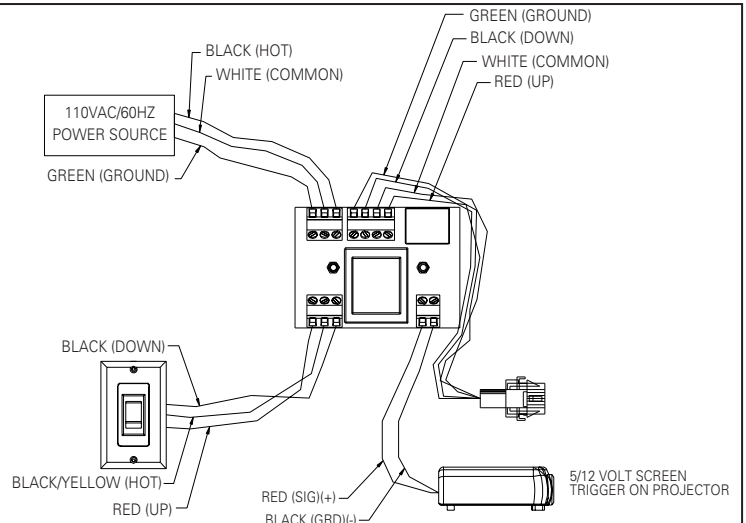

240V WIRING DIAGRAM WITH OPTIONAL BUILT-IN VIDEO PROJECTOR INTERFACE

FIGURE 9

SEE NOTES IN FIGURE 8.

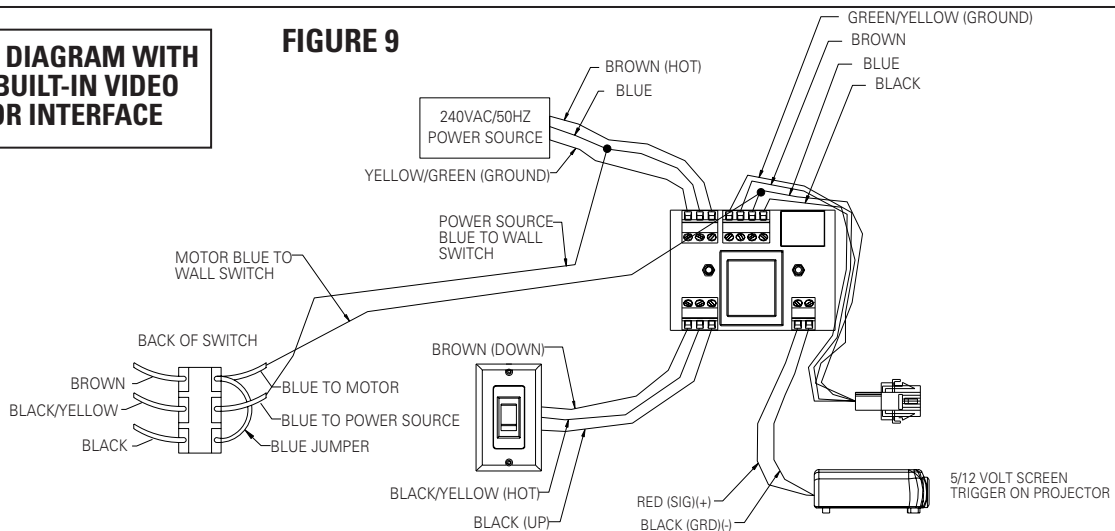

120V WIRING DIAGRAM WITH OPTIONAL BUILT-IN LOW VOLTAGE CONTROL

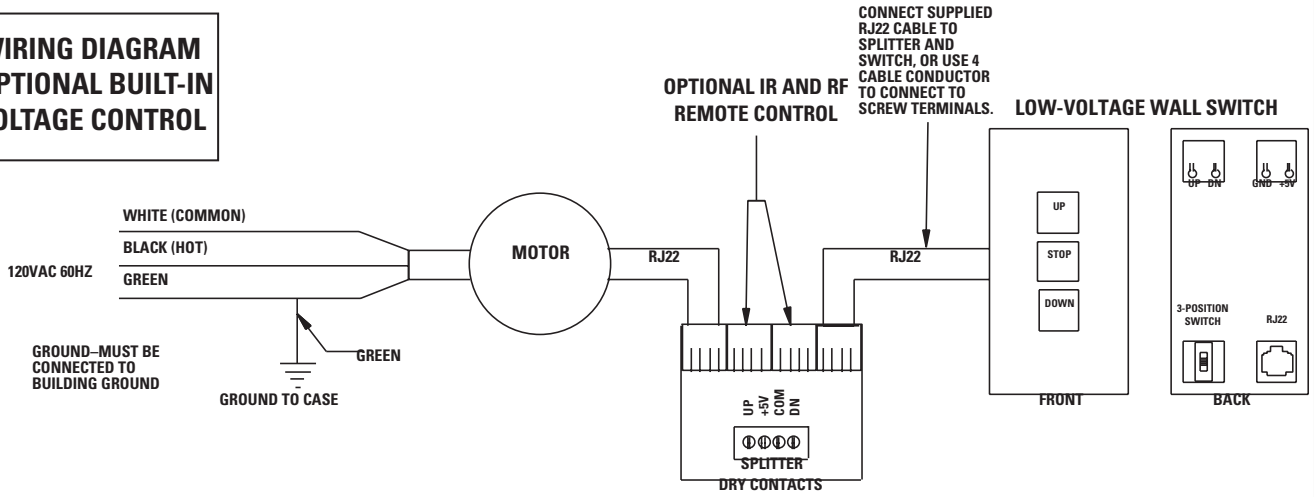

ILT RJ22 PIN-OUTS (TAB IS FACING UP)

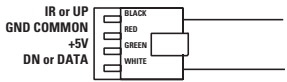

IMPORTANT NOTE: The wall switch is REQUIRED to make any limit switch adjustments, EVEN if a third party control system is used. Therefore, it is advised to wire the switch or provide a 4-conductor connection that is accessible.

FIGURE 10

240V WIRING DIAGRAM WITH OPTIONAL BUILT-IN LOW VOLTAGE CONTROL

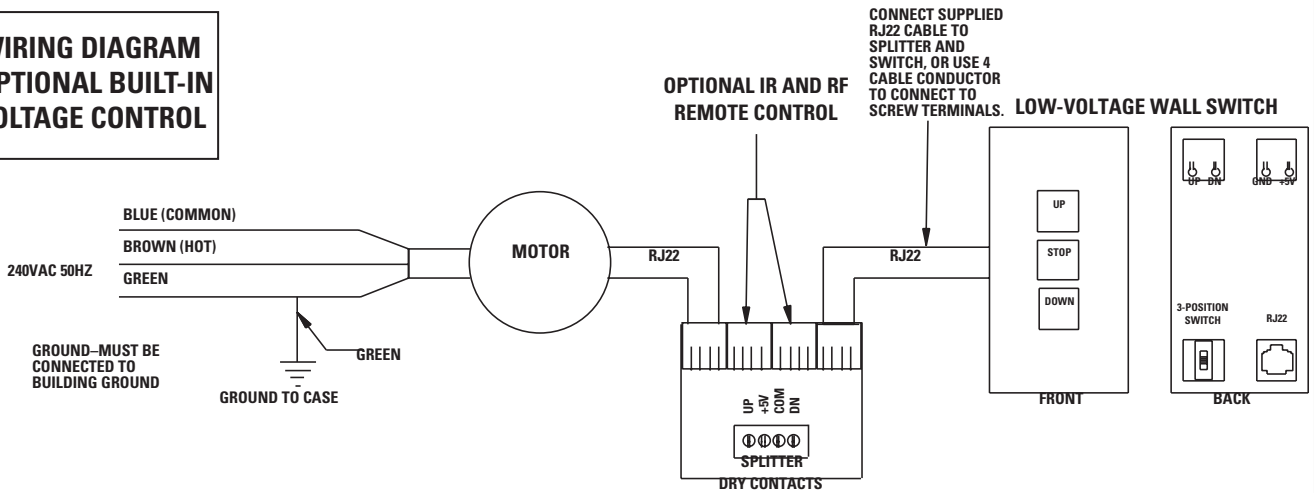

ILT RJ22 PIN-OUTS (TAB IS FACING UP)

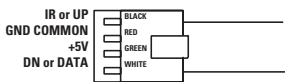

IMPORTANT NOTE: The wall switch is REQUIRED to make any limit switch adjustments, EVEN if a third party control system is used. Therefore, it is advised to wire the switch or provide a 4-conductor connection that is accessible.

FIGURE 11

TROUBLESHOOTING

SYMPTOM	CAUSE	SOLUTION
1. Screen will not operate. Motor does not hum.	<p>(a) Incorrect line voltage.</p> <p>(b) Blown fuse.</p> <p>(c) Tripped circuit breaker.</p> <p>(d) No power to operating switch or junction.</p> <p>Power at junction box</p> <p>(e) Thermal overload tripped.</p> <p>(f) Broken wire in the "down" or "up" position.</p> <p>(g) Defective motor, limit switch or capacitor.</p> <p>(h) Capacitor burned out.</p>	<p>(a) Verify 115-125V (or 220-240V). If insufficient voltage, rewire incoming electric line.</p> <p>(b) Replace fuse.</p> <p>(c) Reset circuit breaker.</p> <p>(d) Check above. Tighten all loose wire connections. Correct any improper connections.</p> <p>"Down" Position Check for power across black and white leads.</p> <p>"Up" Position Check for power across red and white leads.</p> <p>(e) Let motor cool down for 15 minutes. Try again.</p> <p>(f) Check for continuity. Cut off old splice and reconnect.</p> <p>(g) Replace motor assembly. NOTE: Motor is a sealed assembly.</p> <p>(h) Replace motor assembly.</p>
2. Incorrect stopping position in downward direction.	<p>(a) Lost roller wrap.</p> <p>(b) "Down" limit switch out of adjustment</p>	<p>(a) See instructions below.</p> <p>(b) See installation instructions.</p>
3. Incorrect stopping position in upward direction.	<p>(a) Lost roller wrap.</p> <p>(b) "Up" limit switch out of adjustment</p>	<p>(a) See instructions below.</p> <p>(b) Adjust "up" limit switch. Call for information</p>
4. Noise. NOTE: Screen will operate with a low pitched hum.	<p>(a) Gear Noise.</p>	<p>(a) Replace motor assembly.</p>
5. Coasting.	<p>(a) Defective brake.</p>	<p>(a) Replace motor assembly.</p>

RESTORING LOST ROLLER WRAP

1. Tape a strap to the bottom of the screen surface.
2. Push strap over back of roller.
3. Feed fabric as you pull strap to draw fabric over top of roller.
4. Remove tape and strap.