



General Description:

The DPM 4000 allows for audio connections and system expansion through the use of interface card modules. There are three basic types of modules available for the DPM4000. They are:

- Audio Input Modules
- Audio Output Modules
- GPIO Control Modules

Slots 1 and 2, located on the far right of the DPM 4000 (as viewed from the rear), are the DPM 4000's audio input module slots providing two audio inputs per slot. Each slot can be equipped with any suitable audio input module. The DPM 4000 is shipped with no audio input modules installed.

Slots 3 and 4, located to the left of slots 1 and 2, are the DPM 4000's audio output slots providing two audio outputs per slot. Each slot can be equipped with a 2-channel audio output module. The DPM 4000 is shipped with a 2-channel audio output module installed in slot 3 with slot 4 being left empty.

Slot 5, located to the left of slots 3 and 4, is a control slot, which can be equipped with control modules for general control and query purposes. Control modules provide different kinds of control inputs and outputs. The DPM 4000 is shipped with one 8 channel I/O control module installed.

In addition, an extension slot allows retrofitting additional serial ports, which can be used for the inter-communication amongst DPM 4000 managers or to connect additional external devices. For detailed information, please refer to the owner's manuals of the individual extensions or modules.

2-Channel Paging Station Module (NRS 90215)

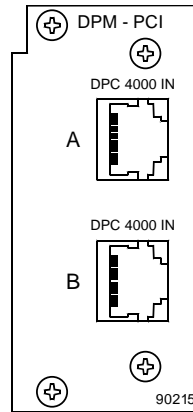

This 2-channel audio input module is meant for the connection of DPC 4000 Series paging consoles. Each of the two input channels provide RJ-45 sockets allowing the connection of up to 4 paging stations plus paging station extensions per input. The microphone terminals are interconnected via 6-conductor parallel cables. The module can be installed in slot 1 and slot 2. Next to the electronically balanced audio input, each input connector provides a serial RS-485 interface

port and the power supply connection for the paging stations (see also: pin-assignment of the RJ-45 connector). The paging stations' power supply employs an electronic, programmable fuse, through which the maximum output current can be matched to meet actual system accommodations. This prevents the entire installation from malfunction, in case of short-circuit occurring in a single paging station only. Input channels can be switched separately onto the monitor bus and you can monitor the audio signal via headphones or loudspeaker, either which is connected to the monitor output. Automatic pilot tone surveillance of the entire input stage is integrated as well. If necessary, retrofitting the audio inputs with transformers is possible.

Specifications:

connection	2 x RJ-45 sockets
inputs	2, electronically balanced
nominal input level	0 dBu / 775 mV
max. input level	+12 dBu / 3 V
input impedance	20 kΩ
input balancing	> -30 dB
frequency response	20 Hz ... 20 kHz, ± 0.5 dB
S/N ratio	> 100 dB (A-weighted)
distortion	< 0.01 %
A/D-conversion	18-bit linear, Sigma-Delta
control interfaces	2 x RS-485 standard
power supply outputs for the DPC 4000	2, short-circuit-proof, electronically programmable fuses
supply voltage	24 V DC (21.6 ... 31.2 V DC)
nominal current	330 mA, 660 mA, 990 mA (adjustable, electronic fuse)
power consumption	2 W
dimensions W x H x D	37.5 x 81 x 248 mm
weight	152 g

MIC/LINE + 2 AUX Input Module (NRS 90216)

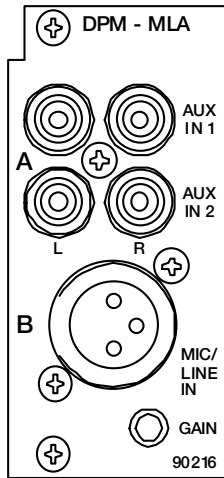

This 2-channel audio input module is meant for the connection of external audio sources of any kind. Channel A employs two switched AUX-inputs with 4 RCA-type connectors (2 x L / R) for CD players, tape decks, tuners, DAT decks, etc. The MIC / LINE-input of channel B is provided through an XLR F-type connector allowing the connection of microphones, mixers and other similar sources. The module can be inserted in slot 1 and slot 2. Input levels of both AUX-inputs can be separately

adjusted via internal potentiometers in a range between -10 dBu to $+12$ dBu. The MIC / LINE-input's sensitivity can also be adjusted through an internal MIC / LINE switch (PAD) providing 30 dB attenuation. The GAIN-control on the appliance's rear panel offers additional control within a range of 40 dB. The MIC / LINE input is electronically balanced and can be retrofitted with a transformer. Phantom power can be switched via a jumper. If necessary, it is also possible to incorporate a compressor/limiter into the audio path via jumper setting. The input channels can be switched separately to the monitor bus and you can listen to the signal via headphones or loudspeaker, either which is being connected to the monitor output. Automatic pilot tone surveillance of the entire input stage is integrated as well.

Specifications:

Connections	1 x XLRF-type / 4 x RCA-type connectors
Input A	2 x AUX, unbalanced, internally summed
nominal input level	-10 dBu ... $+12$ dBu / 250 mV ... 3 V
max. input level	$+12$ dBu / 3 V
input impedance	10 kW
input B	MIC/LINE, electronically balanced
nominal input level	MIC: -54 dBu ... -14 dBu / 1.5 mV ... 155 mV
	LINE: -24 dBu ... $+16$ dBu / 50 mV ... 5 V
max. input level	MIC: $+5$ dBu / 1.4 V
(in limiter operation)	LINE: $+30$ dBu / 25 V
input impedance	MIC: 3.6 kW, LINE: 10 kW
input balancing	> -30 dB
phantom power	24V / 20 mA, switched via jumper
frequency response	20 Hz ... 20 kHz, ± 0.5 dB
S/N ratio	> 95 dB (A-weighted)
distortion	< 0.01 %
A/D-conversion	18-bit linear, Sigma-Delta
power consumption	2.3 W
dimensions W x H x D	37.5 x 81 x 252 mm
weight	160 g

2-Channel MIC/LINE Input Module (NRS 90217)

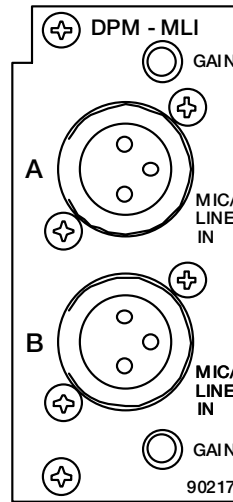

This 2-channel audio input module is meant for the connection of external audio sources, like microphones, mixers, etc. Both channels are furnished with XLR F-type connectors. The module can be installed into slot 1 and slot 2. The sensitivity of the MIC / LINE inputs can be adjusted in a wide range. The internal MIC / LINE switches (PADs) provide 30 dB attenuation. The separate GAIN-controls for each channel provide additional control in a range of 40 dB. The MIC / LINE inputs are electronically balanced and

can be retrofitted with transformers. Phantom power can be switched via jumper setting. If necessary, compressors / limiters can also be incorporated in the audio paths via jumpers. Input channels can be switched separately onto the monitor bus and you can listen to the signal via headphones or loudspeaker, either which is being connected to the monitor output. Automatic pilot tone surveillance of the entire input stage is integrated as well.

Specifications:

connections	2 x XLRF-type connectors
audio	
inputs	2 x electronically balanced
nominal input level	MIC: -54 dBu ... -14 dBu / 1.5 mV ... 155 mV
	LINE: -24 dBu ... $+16$ dBu / 50 mV ... 5 V
max. input level	MIC: $+5$ dBu / 1.4 V
(in limiter operation)	LINE: $+30$ dBu / 25 V
input impedance	MIC:3.6 kW
	LINE: 10 kW
Input balancing	> -30 dB
phantom power	24V / 20 mA, switched via jumper
frequency response	20 Hz ... 20 kHz, ± 0.5 dB
S/N ratio	> 95 dB (A-weighted)
Distortion	< 0.01 %
A/D-conversion	18-bit linear, Sigma-Delta
phantom power	24V / 20 mA, switched via jumper
power consumption	3 W
dimensions W x H x D	37.5 x 81 x 252 mm
D	
weight	160 g

2-Channel AUX Input Module (NRS 90228)

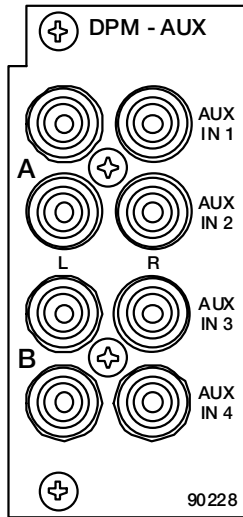

This 2-channel audio input module provides 8 RCA-type connectors (4 x L / R) for connecting external audio sources such as CD-players, tape decks, tuners, DAT decks, etc. The module can be installed into slot 1 and slot 2. The input levels of the four AUX inputs can be independently adjusted in a range between -10 dBu and +12 dBu via internal trim-potentiometers. Input channels can be switched separately to the monitor bus and you can listen to the signal via headphones or loudspeaker, either which

being connected to the monitor output. Automatic pilot tone surveillance of the entire input stage is integrated as well.

Specifications:

connections	8 x RCA-type connectors
inputs	4 x AUX, unbalanced, internally summed
nominal input level	-10 dBu ... +12 dBu / 250 mV ... 3 V
max. input level	+12 dBu / 3 V
input impedance	10 kW
frequency response	20 Hz ... 20 kHz, ± 0.5 dB
S/N ratio	> 100 dB (A-weighted)
distortion	< 0.01 %
A/D-conversion	18-bit linear, Sigma-Delta
power consumption	1.4 W
operational temperature range	+5 °C ... +40 °C
dimensions W x H x D	37.5 x 81 x 252 mm
weight	150 g

MIC/LINE + Paging Station Module (NRS 90234)

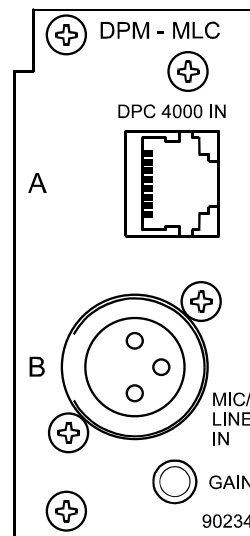

This 2-channel audio input module is meant for the connection of DPC 4000 Series paging stations and other external audio sources. The RJ-45 socket of channel A allows the connection of up to 4 microphone terminals plus paging station extensions. The MIC / LINE input of channel B is furnished through an XLR F-type connector allowing the connection of microphones, mixers and other audio signal sources. The module can be installed into slot 1 and slot 2. Next to the electronically balanced audio input, the DPC 4000 input connector

provides a serial RS-485 interface and the power supply for the connected paging consoles (see also pin-assignment of the RJ-45 connector). The MIC / LINE input employs an internal switch (PAD) providing 30 dB of attenuation. The GAIN-control located on the appliance's rear panel offers additional control in a range of 40 dB. The input is electronically balanced and prepared for retrofitting a transformer. Phantom power can be switched via jumper. If necessary, a compressor / limiter circuit can be incorporated in the audio path.

Specifications:

connections	1 x RJ-45 socket; 1 x XLR F-type connector
input A	DPC 4000, electronically balanced
nominal input level	0 dBu / 775 mV
max. input level	+12 dBu / 3 V
input impedance	20 kW
input B	MIC/LINE, electronically balanced
nominal input level	MIC: -54 dBu ... -14 dBu / 1.5 mV ... 155 mV LINE: -24 dBu ... +16 dBu / 50 mV ... 5 V
max. input level	MIC: +5 dBu / 1.4 V
(in limiter operation)	LINE: +30 dBu / 25 V
input impedance	MIC: 3.6 kW LINE: 10 kW
Phantom power	24V / 20 mA, switched via jumper
input balancing	> -30 dB
frequency response	20 Hz ... 20 kHz, ± 0.5 dB
S/N ratio	> 95 dB (A-weighted)
distortion	< 0.01 %
A/D-conversion	18-bit linear, Sigma-Delta
control interface	1 x RS-485 standard
supply output for the DPC 4000	1, short-circuit-proof, electronic, programmable fuse
supply voltage	24 V DC (21.6 ... 31.2 V DC)
nominal current	330 mA, 660 mA, 990
dimensions W x H x D	37.5 x 81 x 252 mm
weight	165 g

2-Channel LINE Output Module (NRS 90218)

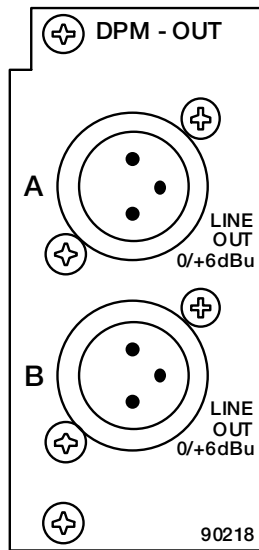

The output module is meant for the connection of power amplifiers with an input sensitivity of 0 dB or +6 dB. Two XLR M-type connectors allow the connection of up to 20 power amplifiers each. The audio signal is electronically balanced; if necessary, transformers can be retrofitted. The module can be installed in slot 3 or slot 4. The output channels can be switched separately to the monitor bus and you can listen to the signal via headphones or loudspeaker, either which is connected to the monitor output. Automatic pilot tone surveillance of the two output

channels is also integrated. The jumpers for adjusting the output voltage to 0 dB or +6 dB are located on the printed board assembly. At the same time you have to alter the jumper setting of the monitor signal correspondingly. The output module employs integrated output relays that prevent switching noise from being heard. When switching the system on, the output signal is put through after the system is been initialized (power-on delay); the contacts are immediately interrupted when switching the power off.

Specifications:

connections	2 x XLRM-type connectors
outputs	2, electronically balanced, transformers are optionally available
nominal output level	0 dBu / 775 mV or +6 dBu / 1.55 V, switched via jumper
output impedance	115 W
frequency response	20 Hz ... 20 kHz, ± 0.5 dB
dynamic range	> 97 dB (A-weighted)
S/N ratio	> 109 dB (A-weighted)
distortion	≤ 0.005 %
D/A-conversion	20-bit linear, Sigma-Delta
power consumption	1.5 W
dimensions W x H x D	37.5 x 81 x 247 mm
weight	160 g

8 I/O Control Module (NRS 90219)

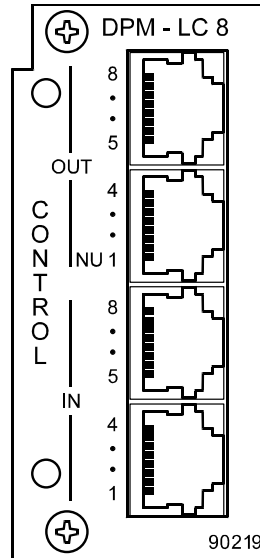

This control module provides 8 floating control inputs and 7 floating logic level outputs (0 V, 24 V). An additional output provides pole change impulses for controlling slave system clocks. Contact is established via 4 x RJ-45 sockets providing 8 contacts each. The module can be installed in slot 5. The slave clock output (NU, OUT 1) is short-circuit proof; up to approximately 40 slave clocks can be connected. Please make sure to connect all slave clocks according to their correct polarity. The control outputs (OUT 2 - 8) are capable of switching

voltages of either polarity and up to a maximum current of 1 A. The control inputs (IN 1 - 8) are capable of handling voltages of either polarity between -31 V and +31 V; for voltages between 0 and 5 V the inputs are not active (low), for voltages between 10 V and 31 V the inputs are active (high). The control inputs can ignite switching functions or macros either during a change of state or in any stationary state. This offers the possibility to monitor line idling currents (e. g. in fire alert system installations).

Specifications:

connections	4 x RJ-45 sockets
logic inputs	8, floating via opto-coupler, bi-polar
voltage when the input is LOW	$U_{IN} < \pm 5$ V
voltage when the input is HIGH	$U_{IN} > \pm 10$ V
maximum input voltage	$U_{IN} \max = \pm 31$ V
logic outputs	7, floating via relay contacts
contact capacity	1 A / 24 V DC
slave clock output	pole change impulse / turning impulse
output voltage	24 V DC
maximum output current	500 mA, electronically protected against overload
power consumption	3.2 W
dimensions W x H x D	37.5 x 81 x 247 mm
weight	195 g

Available Accessories:

Model	Cat. No.	Description
NRS90227	121679	Output Transformer Line Balanced
		Line Balanced Input Transformer
		(1 pc. required per channel)
NRS90233	121682	Input Transformer Mic/Line

Ordering Information:

Model	Cat. No.	Description
NRS90215	121665	2 Input Paging Station Module DPC
NRS90216	121666	Input Module: Mic/Line + 2 x Aux
NRS90217	121667	Input Module: Mic/Line
NRS90218	121668	2 Channel Output Line Module
NRS90228	121680	Input Module: 2 Channel Aux (RCA Phono Connectors)
NRS90234	121736	Input Module: Combination Mic/Line + Paging Console

Block Diagrams:

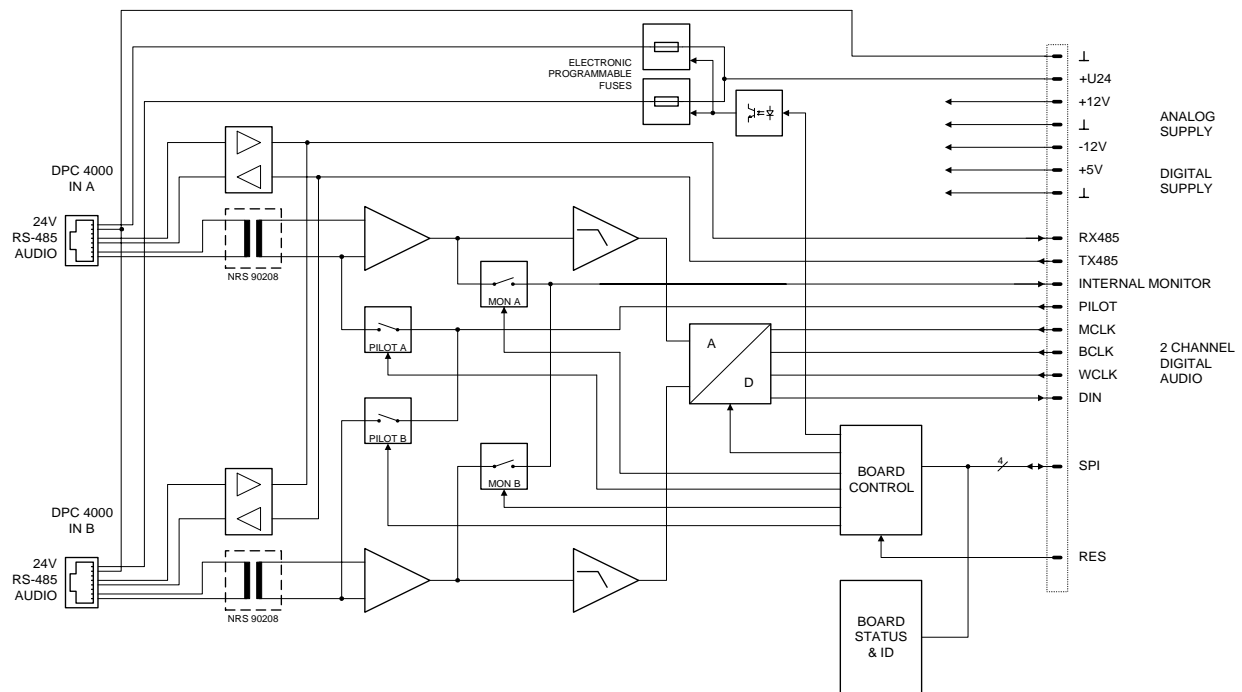

NRS90215 Block Diagram 1

Block Diagrams:

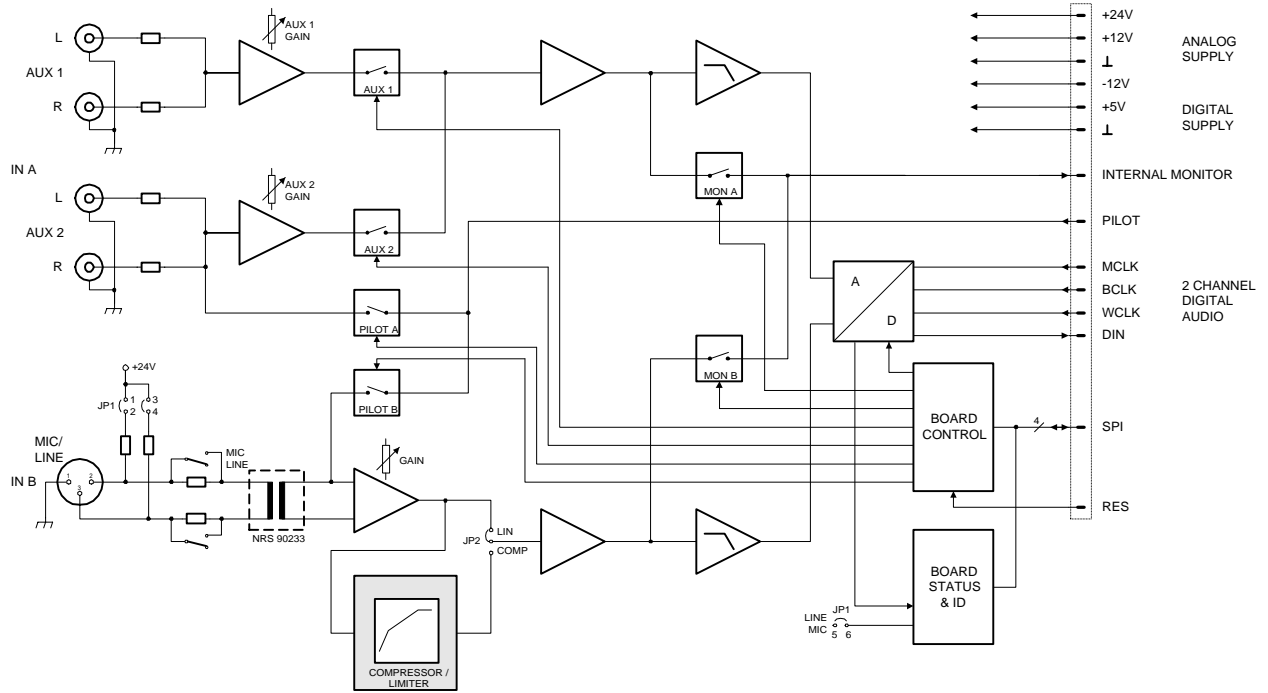

NRS90216 Block Diagram 1

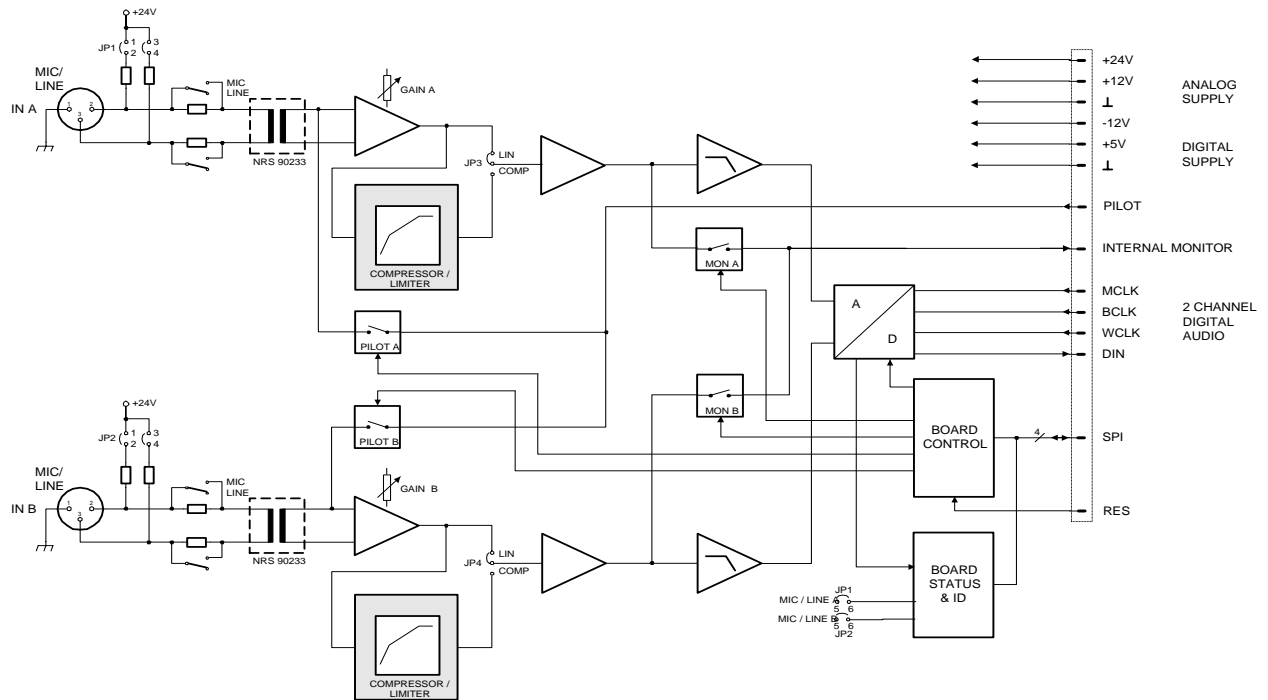

NRS90217 Block Diagram 1

Block Diagrams:

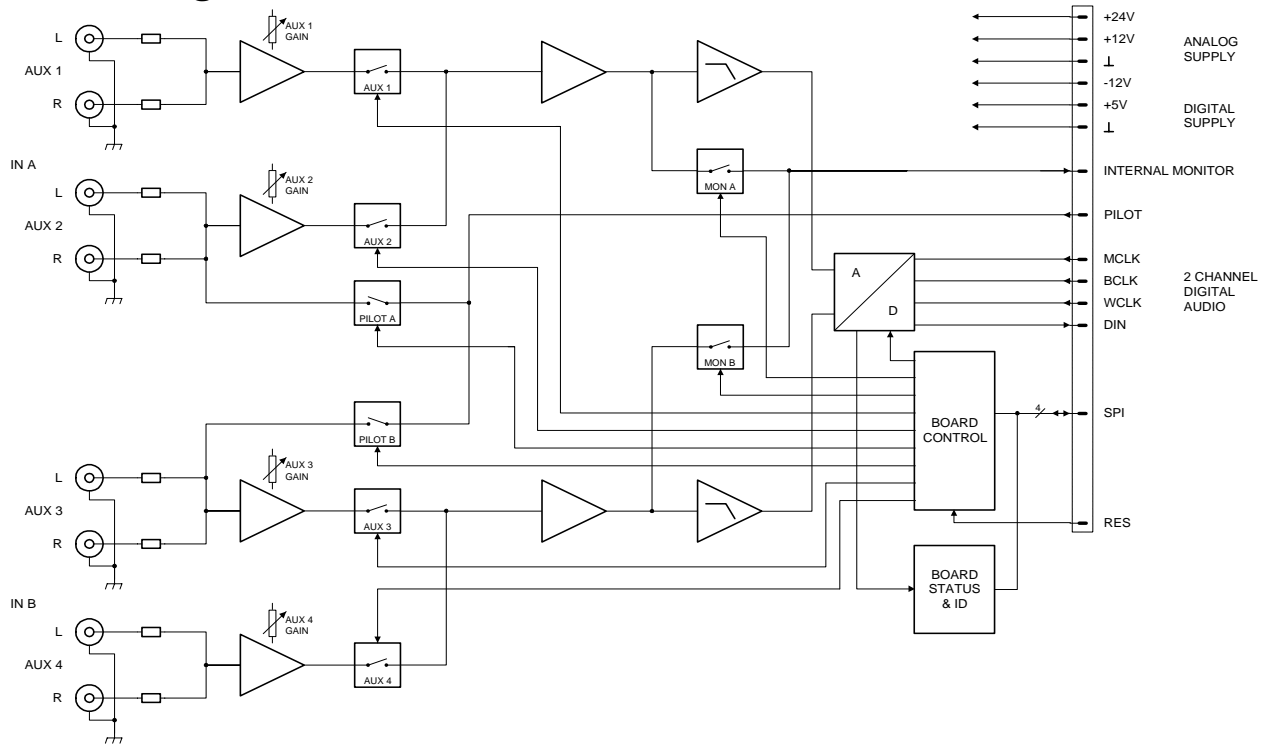

NRS90228 Block Diagram 1

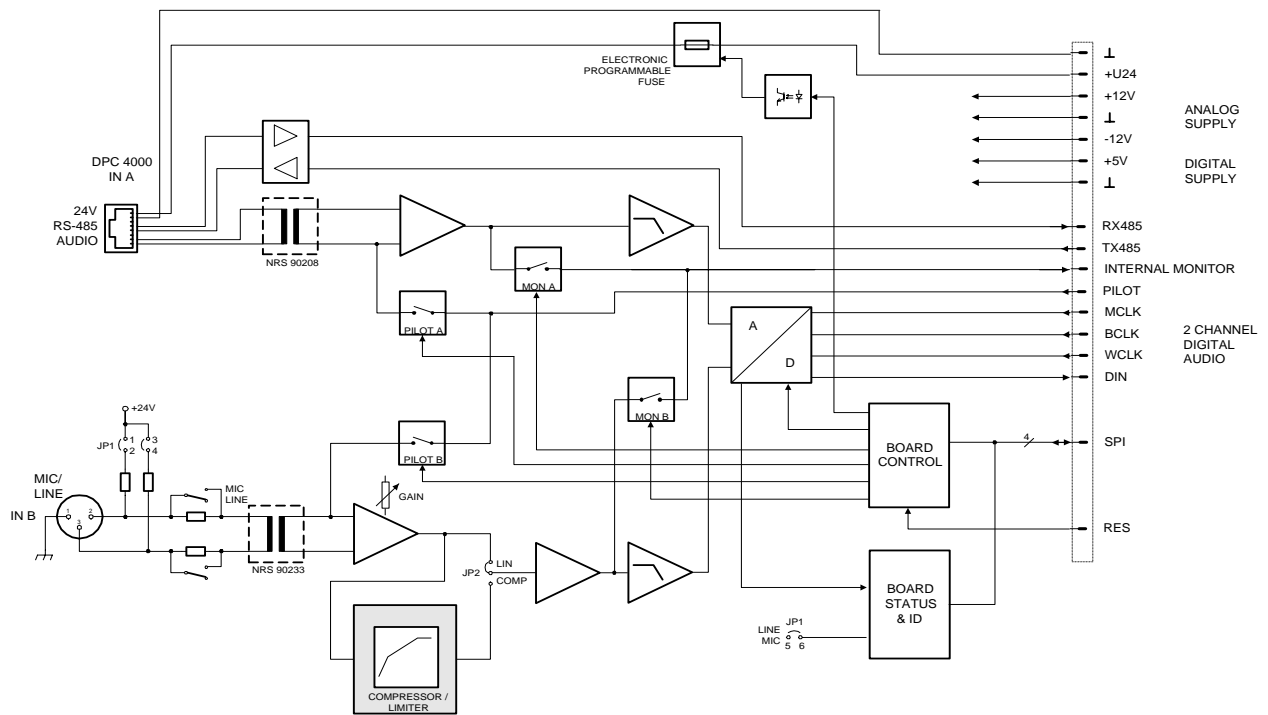

NRS90234 Block Diagram 1

Block Diagrams:

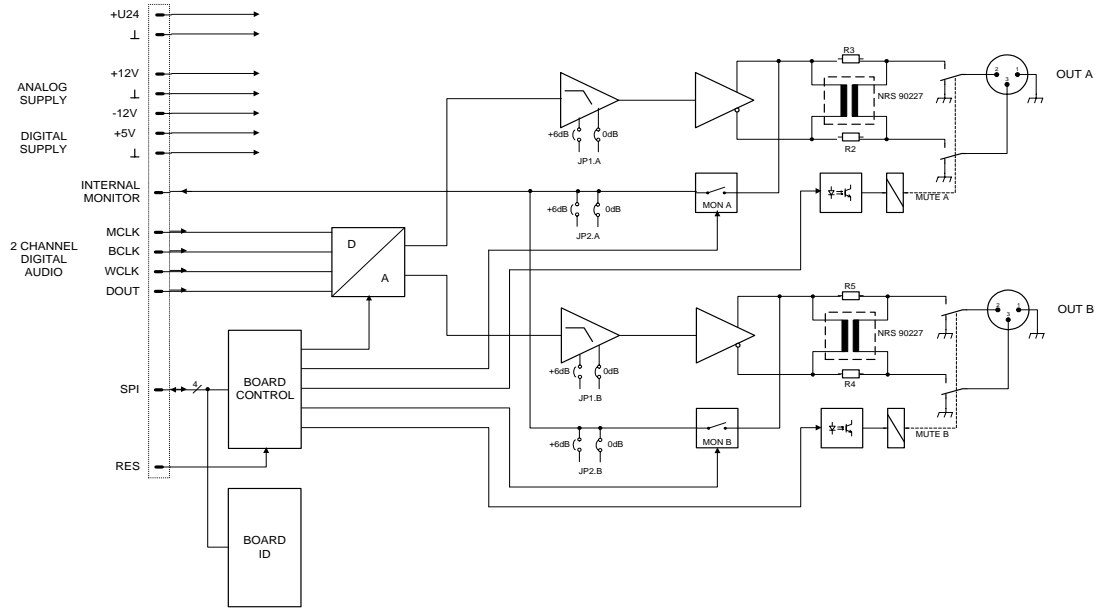

NRS90218 Block Diagram 1

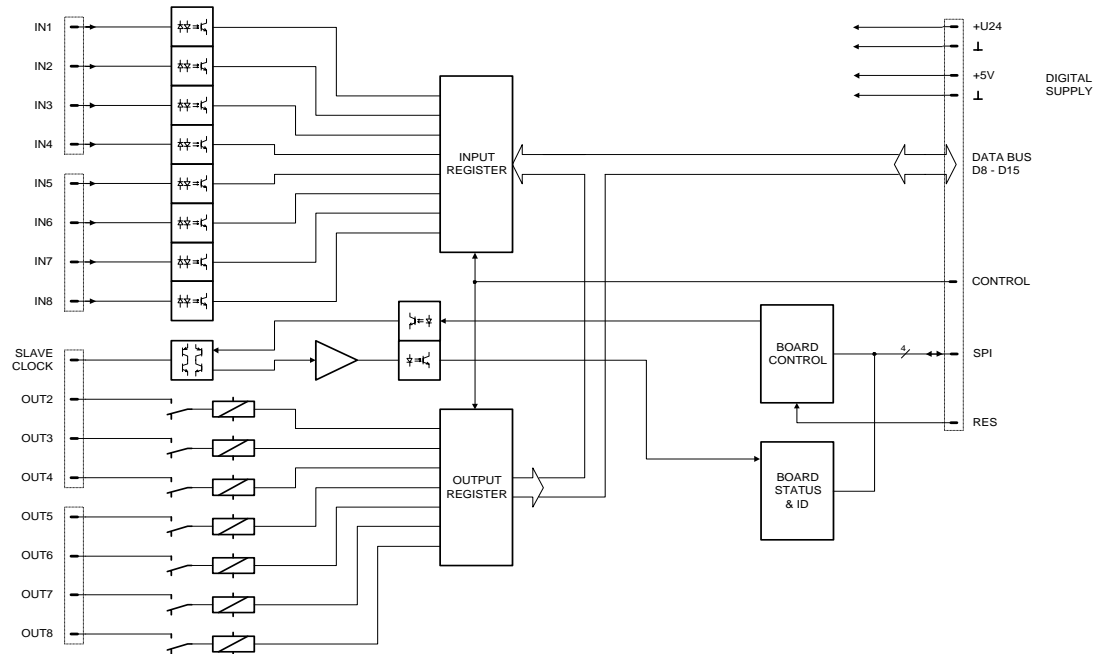

NRS90219 Block Diagram 1



12000 Portland Av. South, Burnsville, MN 55337
 Phone: 952-887-4051, Fax: 952-887-0043
www.electrovoice.com
 Telex Communications Inc 11/2002
 Part Number 38109-xxx Rev A

USA and Canada Only. For customer orders contact
 Customer Service at: 800/392-3497 Fax: 800/955-6831