

The
POWER *In*
PRESENTATION PRODUCTS

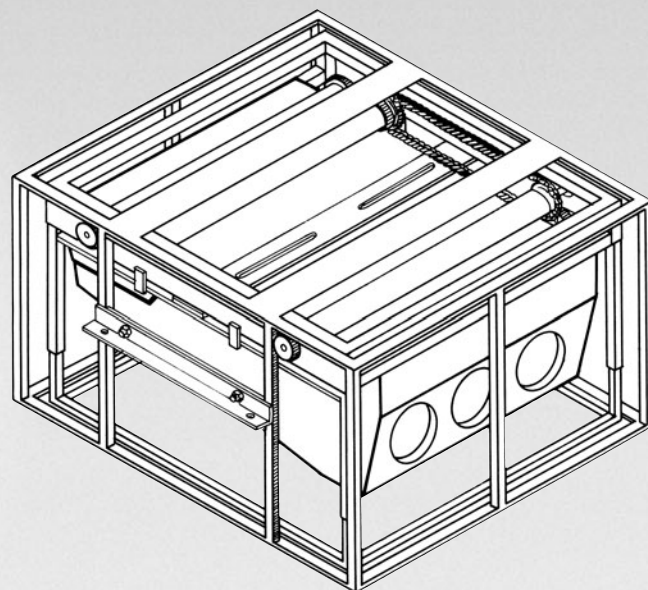

**Installation Instructions for
DA-LIFT PROJECTOR LIFT**



DA-LITE SCREEN COMPANY, INC.

3100 North Detroit Street
Post Office Box 137
Warsaw, Indiana 46581-0137
Phone: 574-267-8101
800-622-3737
Fax: 574-267-7804
www.da-lite.com
e-mail: info@da-lite.com

IMPORTANT SAFETY INSTRUCTIONS

When using your video equipment, basic safety precautions should always be followed, including the following:

1. Read and understand all instructions before using.
2. Position the cord so that it will not be tripped over, pulled, or contact hot surfaces.
3. If an extension cord is necessary, a cord with a current rating at least equal to that of the appliance should be used. Cords rated for less amperage than the appliance may overheat.
4. To reduce the risk of electric shock, do not disassemble this appliance. Contact an authorized service dealer when repair work is required. Incorrect reassembly can cause electric shock when the appliance is used subsequently.
5. The use of an accessory attachment not recommended by the manufacturer may cause a risk of fire, electric shock, or injury to persons.

SAVE THESE INSTRUCTIONS

PRE-INSTALLATION

1. Carefully unpack Da-lift projector lift.
2. Make sure to recheck measurements of projector lift location before installation.

SUGGESTED METHODS OF INSTALLATION

1. MOUNTING DA-LIFT PROJECTOR LIFT BETWEEN JOISTS.

Install the joists at the proper height and width to fit the Da-lift you are installing (see figure 1).

NOTE: The Da-lift must be installed on top of the joists. Be sure to leave access from above for installation.

When the joists are properly installed and secured in place, slide the Da-lift in position. Bolt the two brackets (1-1/2" x 19") to the frame. Lower the unit onto the joists and secure in place. Additional bracing may be required, based on construction.

NOTE: Da-lift projector lift must be installed level!

2. MOUNTING DA-LIFT PROJECTOR LIFT USING 1/2" DIAMETER THREADED RODS.

Secure four 1/2" diameter threaded rods to the ceiling at the dimensions shown in figure 2, "E" and "F". Install the mounting bracket (1-1/2" x 19") to each side of Da-lift with 1/2" diameter bolts, flat washers and nuts. Attach one nut on each rod and run the nut up to the desired height.

Slide Da-lift projector lift up with all (4) four threaded rods into the mounting brackets. Install 1/2" nuts under the mounting brackets. Adjust the frame to the proper height and level with bottom nuts on the rod. Lock the mounting brackets in place with the nuts on the top of each rod. Frame must be level and solid. Additional bracing may be required, based on construction.

SPECIFICATIONS

MODEL	LIFTING CAPACITY	WIDTH A	HEIGHT B	DEPTH C	HEIGHT D	DIM. E	DIM. F
Da-lift 10M	40 lbs.	22-5/8"	15"	22"	4-1/2"	24-1/8"	14"
Da-lift 15M	40 lbs.	22-5/8"	20"	22"	9-1/2"	24-1/8"	14"
Da-lift 15	300 lbs.	30-3/4"	20"	34"	9-1/2"	32-1/4"	16-1/4"
Da-lift 19	300 lbs.	32-3/4"	24"	38"	13-1/2"	34-1/4"	16-1/4"
Da-lift 19L	300 lbs.	42-3/4"	24"	48"	13-1/2"	44-1/4"	16-1/4"

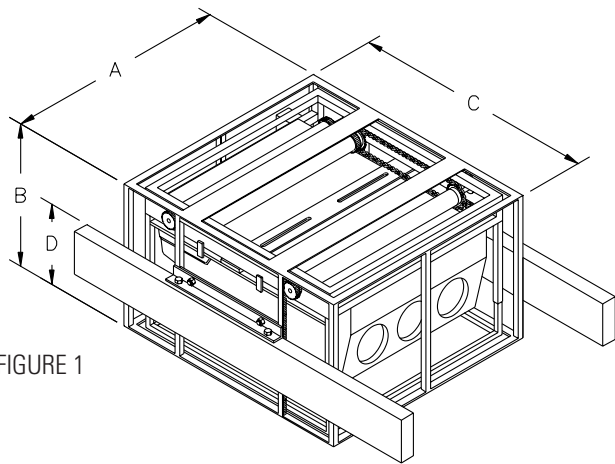

FIGURE 1

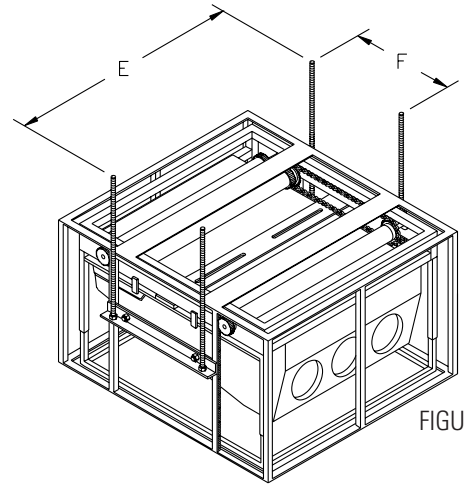

FIGURE 2

ELECTRICAL WIRING

1. Install electrical hook up that applies to your unit. Make sure to review your Electrical Installation Checklist and wiring diagram (see figure 5) for either 120 volt switch, 220/240 volt switch, or DRC low voltage control.

NOTE: Da-lift projector lift has been internally wired at Da-lite. External wiring is completed by installer conforming to local and national codes. Be sure the wires are long enough for the Da-lift to go up and down.

2. Test installation by carefully running Da-lift “up” and “down” several times. Be prepared to stop Da-lift.
3. Make sure Da-lift stops in the up direction flush with the ceiling.

DA-LIFT PROJECTOR LIFT ADJUSTMENT

Models 15, 19, 19L

Da-lift projector lift travel is stopped automatically in the full up and full down positions by limit switches, which have been properly adjusted at the factory. The up limit switch should not be field adjusted. If it is necessary to readjust the down limit switch, proceed in the following manner (see figure 3). Raise projector lift before adjustment for less drop. Take a small screwdriver or 5/32" hex wrench and insert in yellow switch and turn towards the (-) or clockwise direction. Raise and then lower the Da-lift and check for proper stopping height. If additional change is necessary, repeat steps until the proper height is set. Check for satisfactory condition by operating unit a few times.

The bottom frame of the Da-lift is removable and adjustable to ceiling level. Finish the bottom frame to match the ceiling.

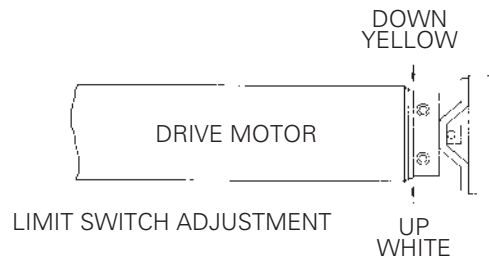

FIGURE 3

Models 10M, 15M

Use a small screwdriver or 5/32" hex wrench and insert in number 2 switch. Turn clockwise for less drop. Check for proper stopping height. Repeat steps until the proper height is set (see figure 4).

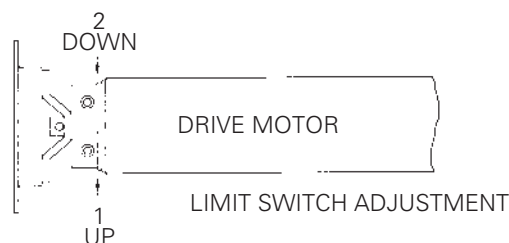
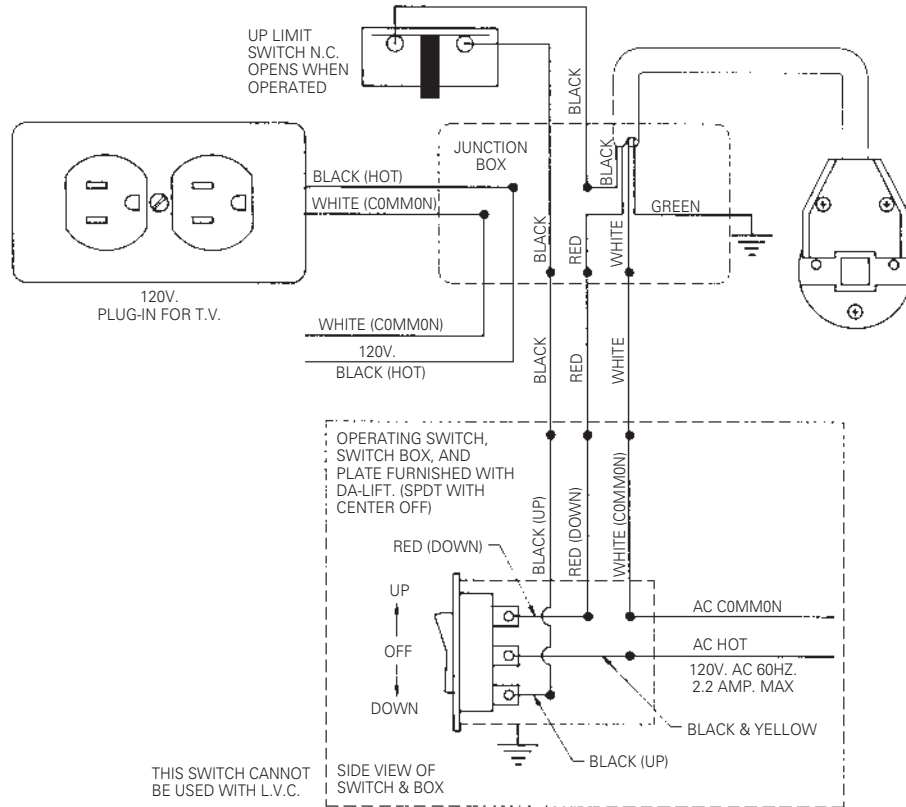

FIGURE 4

DA-LIFT PROJECTOR LIFT INSTRUCTIONS

120V WIRING DIAGRAM



220 / 240V WIRING DIAGRAM

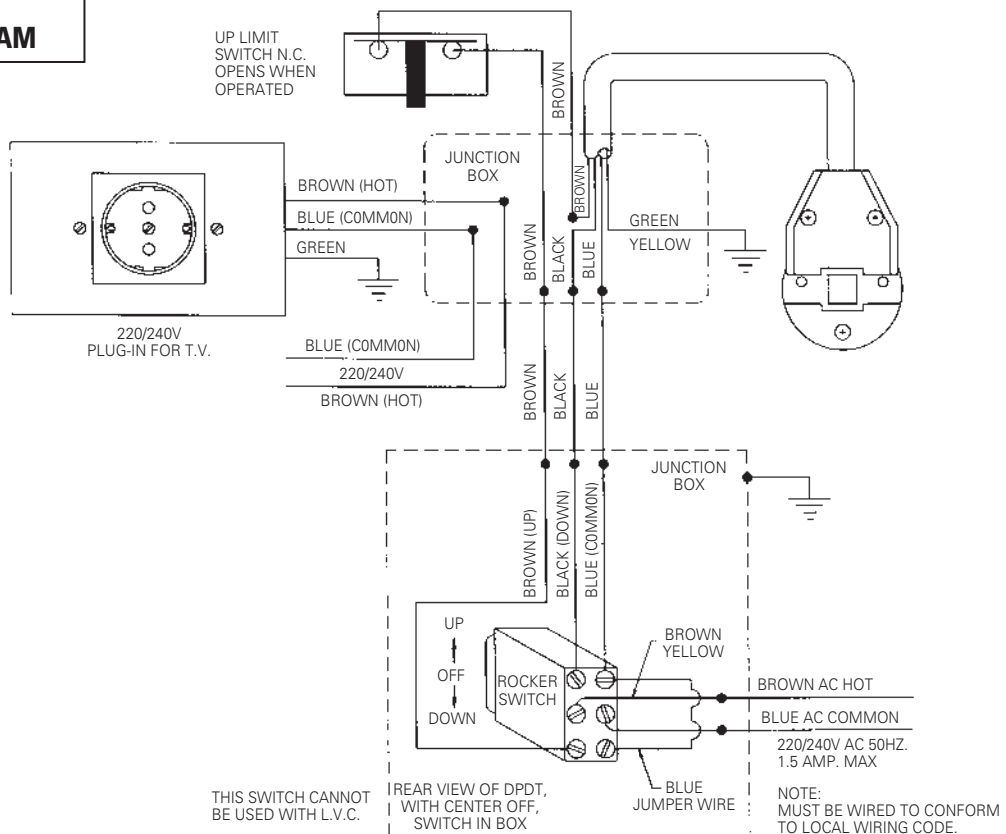

FIGURE 5