



Aktuelle Informationen zu Sennheiser-Produkten erhalten Sie auch im Internet unter „<http://www.sennheiser.com>“.

For up-to-date information on Sennheiser products, you can also visit the Sennheiser Web site at “<http://www.sennheiser.com>”.

Vous trouverez également toutes les informations actuelles relatives aux produits Sennheiser sur Internet à l'adresse Web “<http://www.sennheiser.com>”.

Informazioni attuali sulla gamma di prodotti Sennheiser sono disponibili anche in Internet al sito “<http://www.sennheiser.com>”.

También en Internet, bajo “<http://www.sennheiser.com>” obtendrá Vd. informaciones actuales sobre los productos Sennheiser.

Actuele informatie met betrekking tot Sennheiser producten vindt u ook op Internet onder “<http://www.sennheiser.com>”.

Diese Service-Nummer gilt nur für Deutschland:

K.I.S.S.
Kunden-Information-System-Sennheiser
0180 / 5221539
0,12 Euro / Min.
Mo - Fr 8.00 - 18.00 Uhr



Sennheiser electronic GmbH & Co. KG
D-30900 Wedemark

Printed in Germany

Publ. 06/02

Telefon 05130/600-0
Telefax 05130/600-300

82582 / A01



GEBRAUCHSANLEITUNG
INSTRUCTIONS FOR USE
NOTICE D'EMPLOI
ISTRUZIONI PER L'USO
INSTRUCCIONES DE USO
GEBRUIKSAANWIJZING

MD 42





MD 42 DYNAMISCHES MIKROFON

Hochwertiges Handmikrofon mit Kugelcharakteristik. Entwickelt für den rauen Einsatz bei Reportagen, für Funk und Fernsehen. Einfach zu handhaben - der spezielle Aufbau vermeidet Probleme mit Wind und Körperschall.

MERKMALE

- Hohe Sprachverständlichkeit durch optimierten Frequenzgang
- Handlich und stabil durch einen speziell konstruierten Griff
- Gute Aufnahmequalität
- Besonders unempfindlich gegen Körperschall
- Erhöhter Schutz gegen Wind- und Popgeräusche durch doppelte Gaze-Einlage im Einsprachekorb

ZUBEHÖR (NICHT IM LIEFERUMFANG)

- Schnellwechsellamme MZQ 800, Art.Nr. 04711
 - Windschutz MZW 5000 (schwarz), Art.Nr. 03824
 - Windschutz MZW 65 PRO (schwarz, velourisiert), Art.Nr. 03757
- Sonderfarben und Bedruckung auf Wunsch. Bestellung über den zuständigen Sennheiser-Vertragshändler.

TECHNISCHE DATEN

Akustische Arbeitsweise	Druckempfänger
Übertragungsbereich	40 - 18.000 Hz
Richtcharakteristik	Kugel
Feldleerlauf-Übertragungsfaktor bei 1kHz	2,0 mV/ Pa \pm 2,5 dB (= -54 dBV mit 0 dB = 1 V/Pa) (= -74 dBV mit 0 dB = 1 V/ μ bar; USA)
Nennimpedanz bei 1 kHz	350 Ω
Min. Abschlussimpedanz	1000 Ω
Magnetfeldstörfaktor bei 50 Hz	\leq 1 μ V/ μ T
Stecker	3-pol. XLR-3-Stecker
Maße / Gewicht	\varnothing 49 mm, Länge 250 mm / ca. 360 g
Lieferumfang	Mikrofon MD 42

Änderungen vorbehalten
Kunden-Informationssystem-Sennheiser 01805/221539 (12 Euro/Min)



MD 42 DYNAMIC MICROPHONE

High-quality hand-held microphone with omni-directional pick-up pattern. Designed for rugged use in radio and TV reporting. Easy to handle - the special design minimizes wind and handling noise.

CHARACTERISTICS

- Excellent speech clarity due to optimised frequency response.
- Specially designed rugged housing for tough use.
- Good recording results.
- Excellent rejection of handling noise.
- Special protection against wind and pop noise due to double layer sound inlet basket.

RECOMMENDED ACCESSORIES (NOT SUPPLIED)

- Quick release clamp MZQ 800, Cat. No. 04711.
 - Foam windshield MZW 5000 (black), Cat. No. 03824.
 - Foam windshield MZW 65 PRO (black, velour), Cat. No. 03757.
- Other colours and imprints are available on request, please order from your local Sennheiser dealer.

TECHNICAL DATA

Acoustic principle	Pressure microphone
Frequency response	40 - 18,000 Hz
Pick-up pattern	Omni-directional
Sensitivity (free field, no load) at 1 kHz	2.0 mV/Pa \pm 2.5 dB (= -54 dBV with 0 dB = 1 V/Pa) (= -74 dBV with 0 dB = 1V/ μ bar;USA)
Nominal impedance at 1 kHz	350 Ω
Min. terminating impedance	1000 Ω
Magnetic field interference factor	\leq 1 μ V/ μ T
Connector	3-pin XLR connector
Dimensions / weight	\varnothing 49 mm, length 250 mm / approx. 360 g
Delivery includes	MD 42 microphone

Subject to alterations





POLARDIAGRAMM
 PICK-UP PATTERN
 DIAGRAMME DE LA DIRECTIVITÉ
 DIAGRAMMA POLARE
 DIAGRAMA DE LA DIRECTIVIDAD
 POOLDIAGRAM

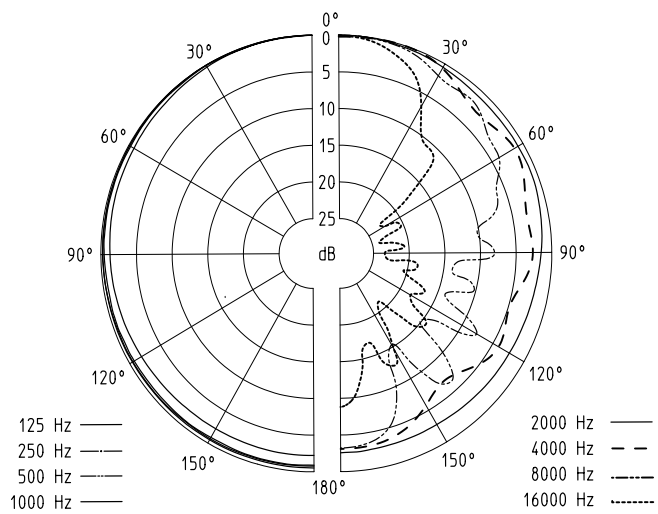

ANSCHLUSS DES MIKROFONS
 CONNECTION
 RACCORDAMENTO DU MICROPHONE
 COLLEGAMENTO
 CONEXION
 AANSLUITING

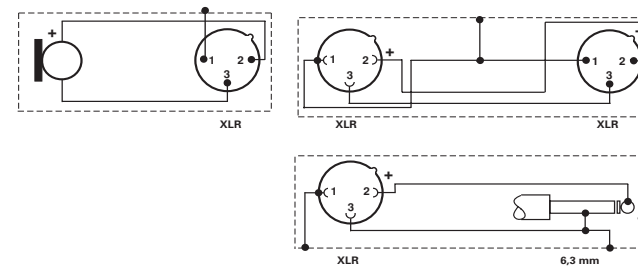
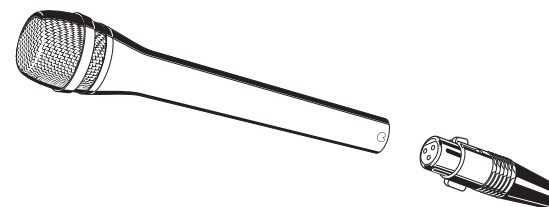



SOLL-FREQUENZGANG
NOMINAL FREQUENCY RESPONSE
COURBE DE RÉPONSE
RISPOSTA ARMONICA NOMINALE
RESPUESTA NOMINAL
STREEFWAARDE-FREQUENTIEKARAKTERISTIEK

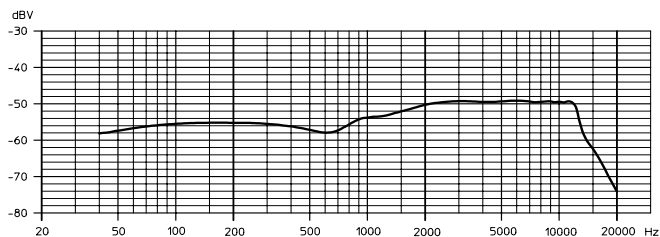

KONFORMITÄTSERKLÄRUNG

Sennheiser electronic GmbH & Co. KG erklären, daß dieses Gerät die anwendbaren CE-Normen und Vorschriften erfüllt.

APPROVAL

Sennheiser electronic GmbH & Co. KG declare that this device is in compliance with the applicable CE standards and regulations.

CERTIFICATION

Sennheiser electronic GmbH & Co. déclarons que cet appareil est en conformité avec les normes CE.

CERTIFICAZIONE

Sennheiser electronic GmbH & Co. KG dichiara che questo apparecchio risponde alle normative e alle prescrizioni CE applicabili.

AUTORIZACION

Sennheiser electronic GmbH & Co. KG declara que este aparato cumple las normas y directrices de la CE aplicables.

VERGUNNING

Sennheiser electronic GmbH & Co. KG verklaren, dat dit toestel voldoet aan de toepasselijke CE-normen en voorschriften.

