

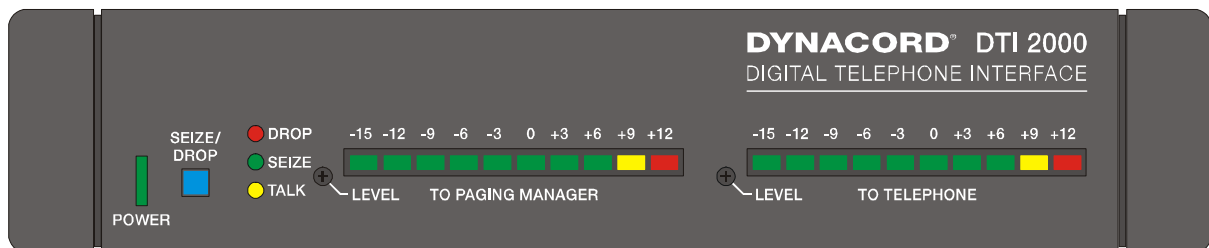

Owner's Manual

DTI 2000

DIGITAL TELEPHONE INTERFACE



Contents

*** Inhaltsverzeichnis

Introduction

This owner's manual covers the installation, programming, and operation of DYNACORD's DTI 2000 Digital Telephone Interface. Since operating and programming the DTI 2000 is similar to the operation and programming of a paging console, the DPM 4000 System handbook, the DPC 4000 paging console owner's manual, and the Help Files of the PC Designer software may also be useful information sources.

Characteristics

The DTI 2000 is a micro processor-controlled, completely configurable telephone interface for DYNACORD PA-systems and sound reinforcement systems. The DTI 2000 is used for connecting the DPM 4000 System Manager to a telephone line or network to launch announcements from each telephone set over the loudspeaker network and to trigger signals, pre-recorded text messages and control functions (macros) of the DPM 4000 System Manager using a telephone set.

The DTI 2000 needs to be connected to an analogue phone line and is controlled via tone-dial (multi-frequency dialling). Using the supplied cable, the telephone interface has to be connected to a paging console input on the DPM 4000. The interface transmits serial control data as well as LF-audio signals. The DTI 2000 appears at the DPM 4000 as a special paging console allowing it to be programmed via the PC Designer Software in paging console dialog mode.

The DTI 2000 offers 100 call numbers (from 00 to 99). Any function can be assigned to any call number. Possible functions include zone or group selection, live-announcements with pre-programmable priority and pre-chime signal, playback of pre-recorded text messages and triggering of DPM 4000 macros. The DTI 2000 offers two different access authorisations with individual password protection. Depending on the actual application and desired operation, the DTI 2000 allows initiating any possible function from a standard telephone set – from making a simple announcements up to triggering a sound reinforcement installation's most complex sequential control procedures.

Features

- Selection of up to 100 zones for announcements
- Programming of up to 20 call groups for group calls and collective calls
- Configuration of a call number organisation chart of up to 100 numbers (0 ... 99) for announcements and arbitrary control functions
- Selecting several zones or groups for announcements
- Initiating the playback of pre-recorded text messages
- Triggering of special functions (macros, erase zone / group selection)
- Assigning priorities for announcements and message playback
- Two level password protection
- Acknowledgement signals for O.K., faulty entry, busy, outgoing text message, etc.
- Automatic hang up: to specify the duration of announcements via internal Dip switches
- Trimmer on the front panel for setting the audio signal level
- Programming via PC Designer Software equivalent to DPC 4000 paging consoles
- Configuration possibility for world telephone standards (country-specific settings)

Controls and Connections

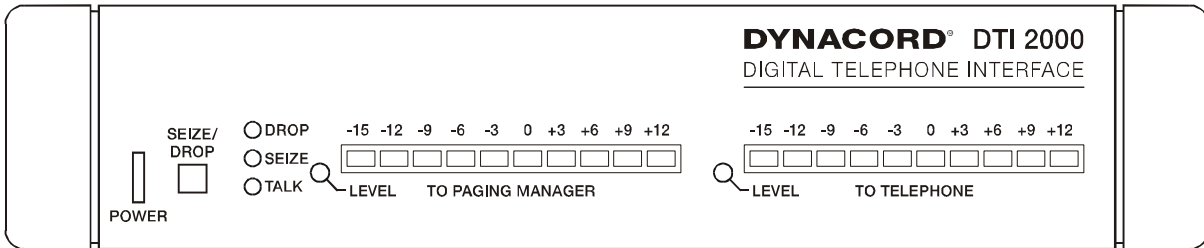

front view

1. POWER indicator

The POWER LED lights when the DTI 2000 receives power input from the supplied power supply unit, which allows worldwide connection and use because it accepts input voltages between 85V AC and 250V AC.

2. SEIZE / DROP key (*SELECT*)

This key allows manually accepting or cancelling phone calls and is mostly used for testing. When an incoming phone call is present (ringing), pressing the SEIZE / DROP key establishes the connection (picks up). Pressing the SEIZE / DROP key again cancels (hangs up) a live connection. Since the DTI 2000 automatically picks up any incoming call respectively automatically hangs up when the remote call is terminated, this key is basically not needed during normal operation.

3. DROP and SEIZE indicators

The red DROP LED indicates that there are no live connections (i.e. the DTI 2000 is on-hook). The green SEIZE LED indicates that the DTI 2000 established a connection to the calling party (i.e. the DTI 2000 is off-hook). The DTI 2000 automatically connects to incoming phone calls. Using the internal DIP-switch S202 allows specifying the number of rings prior to accepting a call.

4. TALK indicator

The orange TALK LED lights whenever the DTI 2000 is in announcement mode (i.e. when an announcement into a single or several zones of the PA-system has been initiated via telephone connection).

5. LEVEL control / meter bars

Audio signals that are transmitted from the DTI 2000 to the DPM 4000 System Manager can be monitored using the TO PAGING MANAGER meter bar. Level adjustment is possible via the associated LEVEL control on the front panel using a small screwdriver. The level setting range is between ***dB (counter clockwise stop) and ***dB (clockwise stop).

Currently, the TO TELEPHONE indicator and the associated level control are not used.

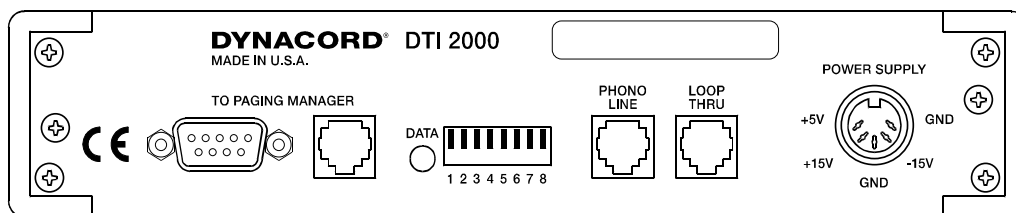

Rear

6. TO PAGING MANAGER connectors, female

The two TO PAGING MANAGER connectors represent the interface to the DPM 4000 System Manager. Using either the 9-pole D-Sub connector or the 6-pole RJ-12 socket (simultaneous use of both terminals is not possible) to establish audio and data connection to the DPM 4000 is possible. The DTI 2000 needs to be connected to one of the paging console inputs (DPC IN, RJ-45 socket) on the DPM 4000. The needed interface cable (RJ-12 to RJ-45) with a length of 3.5m is supplied.

7. DATA indicator

The DATA LED indicates that data is being transmitted between DTI 2000 and DPM 4000 System Manager. Therefore, it serves as main monitoring indicator for correct data connections.

8. DIP switch for address and operation mode settings

The DTI 2000 allows setting an address between 1 and 16. CAUTION: Make sure never to connect two or more appliances with identical address settings to the DPM 4000 System Manager, since this would inevitably result in data conflicts. This also includes the address settings of the connected paging consoles.

Please refer to the chapter DIP-switch settings for further details.

9. Phone sockets

Two telephone connectors are located on the rear panel of the DTI 2000. Connect the PHONE LINE socket with your telephone wall outlet. The LOOP THRU socket offers connection for a telephone set.

10. POWER SUPPLY connector

Connect the supplied power supply unit to this connector by inserting the round plug of power supply unit into the POWER SUPPLY socket on the rear panel of the DTI 2000. Turn the plug's locking ring in clockwise direction to establish a reliable connection. Afterwards, connect the supplied mains cord to the power supply unit before inserting the mains plug into a mains wall outlet.

Se Up and Connections

1. Unpacking

The DTI 2000 package contains the following parts:

- 1 DTI 2000 Digital Telephone Interface
- 1 power supply unit, 100 – 240V AC
- 1 IEC mains cord
- 1 interface cable for DPM 4000 connection, RJ-12 to RJ-45
- 1 telephone cable, RJ-11 to TAE
- 1 owner's manual

Make sure that everything is complete and that nothing is damaged. Otherwise, immediately contact your dealer or the TELEX / EVI Audio service department.

2. DIP switch settings

The DTI 2000 provides a single DIP-switch on the rear panel and two internal DIP-switches. These switches are meant for making specific basic settings, which have to be made before operating the appliance for the first time. Generally, no changes need to be made during the later operation.

2.1 DIP switch for address and operation mode settings on the rear panel (S201)

A switch is "OFF" when it is set to its upper position. Consequently the ON-position is down.

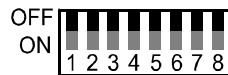

The following table shows how to set addresses using the switches 1 – 4:

SW1	SW2	SW3	SW4	ADDRESS
OFF	OFF	OFF	OFF	1
ON	OFF	OFF	OFF	2
OFF	ON	OFF	OFF	3
ON	ON	OFF	OFF	4
OFF	OFF	ON	OFF	5
ON	OFF	ON	OFF	6
OFF	ON	ON	OFF	7
ON	ON	ON	OFF	8
OFF	OFF	OFF	ON	9
ON	OFF	OFF	ON	10
OFF	ON	OFF	ON	11
ON	ON	OFF	ON	12
OFF	OFF	ON	ON	13
ON	OFF	ON	ON	14
OFF	ON	ON	ON	15
ON	ON	ON	ON	16

CAUTION:

Make sure never to connect two or more appliances with identical address settings to the DPM 4000 System Manager, since this would inevitably result in data conflicts. This also includes the address settings of the connected paging consoles.

Switches 5 – 7 provide no function and should be left in their OFF-position (up).

Switch 8 serves for switching between normal operation and download mode. Leave this switch (SW8) in its OFF-position (up) for normal operation. Download mode is meant for updating the software and loading country-specific settings by DYNACORD or one of its service centers.

SW8	DTI 2000 MODE
OFF	Normal
ON	Download

2.2 Internal DIP switches (S202 and S203)

To make any changes to the internal DIP-switch settings, you first have to remove the cover plate by loosening/removing the screws on the rear panel, as indicated in the diagram below.

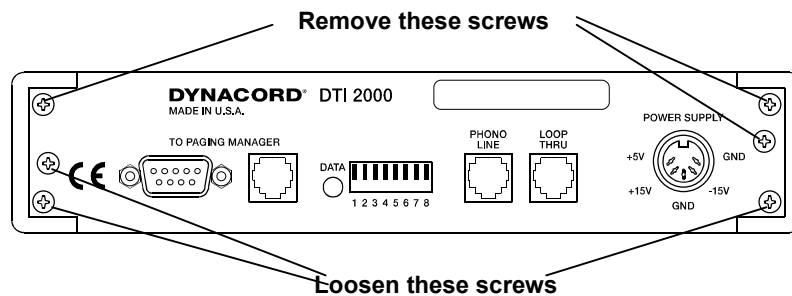

Slightly lift the cover plate at the rear and remove it. Now you are able to change the DIP-switch settings.

For installing the cover plate back in place, first position the case top in the guidance slots of the case bottom and slide it in as far to the front until it rests in place. Put the screws back in place and tighten them. Do not forget to tighten the previously loosened screws.

The following picture shows the positions of DIP-switches S202 and S203:

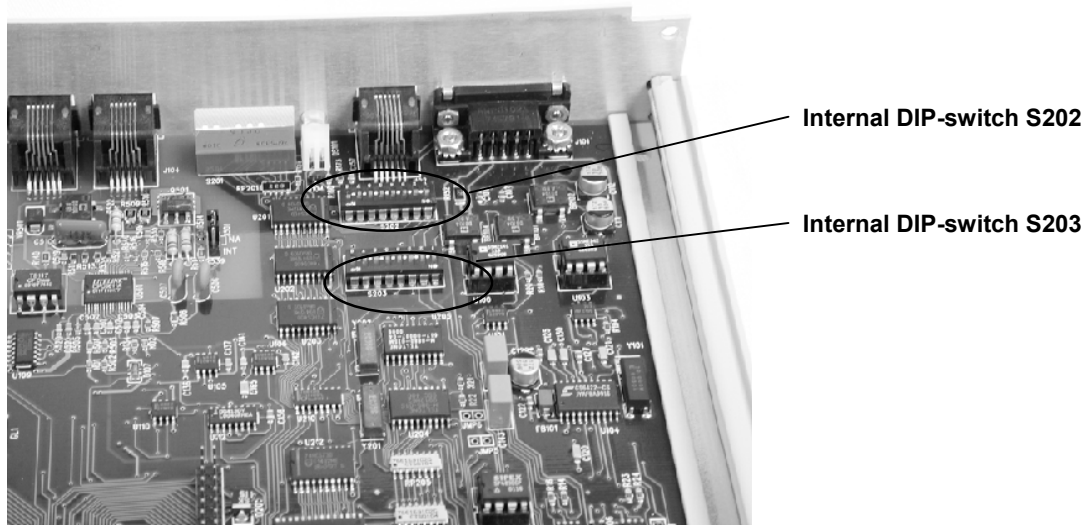

DIP-switch S202 allows setting the ring count, which controls the number of rings before the DTI 2000 automatically picks up and establishes a connection. To change the ring count use the switches 1 - 2. The DTI 2000 is factory pre-set to accept an incoming call after one ring (SW1 & SW2 = OFF).

SW1	SW2	RING COUNT
OFF	OFF	1
ON	OFF	2
OFF	ON	4
ON	ON	8

Switches 3 – 8 are not used and should be left in their OFF-position.

The setting of DIP-switch S203 determines the timeout of a connection (i.e. before the DTI 2000 automatically hangs up). This ensures that phone line and PA-system are not blocked any longer

than the specified maximum connection timeout setting allows. If the caller does not enter any new selection during the connection timeout, the DTI 2000 automatically finishes the momentary announcement and releases the PA-system. Afterwards, the telephone connection is disconnected as well.

Switches 1 – 4 are used to set the maximum timeout for a connection as indicated in the following table:

SW1	SW2	SW3	SW4	TIMEOUT
OFF	OFF	OFF	OFF	OFF
ON	OFF	OFF	OFF	20 sec.
OFF	ON	OFF	OFF	30 sec.
ON	ON	OFF	OFF	45 sec.
OFF	OFF	ON	OFF	60 sec.
ON	OFF	ON	OFF	75 sec.
OFF	ON	ON	OFF	1.5 min.
ON	ON	ON	OFF	2 min.
OFF	OFF	OFF	ON	2.5 min.
ON	OFF	OFF	ON	3 min.
OFF	ON	OFF	ON	3.5 min.
ON	ON	OFF	ON	4 min.
OFF	OFF	ON	ON	5 min.
ON	OFF	ON	ON	6 min.
OFF	ON	ON	ON	8 min.
ON	ON	ON	ON	10 min.

CAUTION:

The DTI 2000 is factory pre-set to a maximum connection timeout of 1.5 minutes (SW1 = OFF, SW2 = ON, SW3 = ON, SW4 = OFF).

Setting the switches 1 – 4 to their OFF-position specifies an infinite timeout, i.e. the connection is not automatically disconnected.

Switches 5 – 8 are not in use and should be left in their OFF-position.

3. Rack installation

There are two rack-mounting options for the DTI 2000. Use the MCP-2 rack installation kit for installing a single DTI 2000 and the MCP-1 for installing two units next to each other in a rack system. The following diagram shows both options.

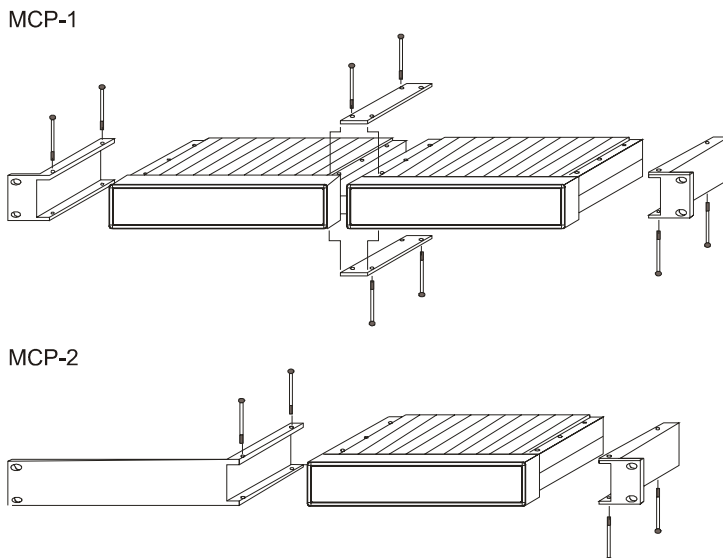

4. Connections

4.1 Connecting the DPM 4000 System Manager

Use one of the TO PAGING MANAGER sockets (not both simultaneously) for connecting the DTI 2000 to the DPM 4000. The DTI 2000 needs to be connected to a paging console input (DPC IN, RJ-45 socket) of the DPM 4000 using the supplied, 3.5m long interface cable (RJ-12 to RJ-45). The following diagrams show the pin-assignment of sockets and cables. The LED labelled DATA is located next to the sockets. This LED lights during active data transmission between DTI 2000 and DPM 4000 System Manager providing indication of a correct connection.

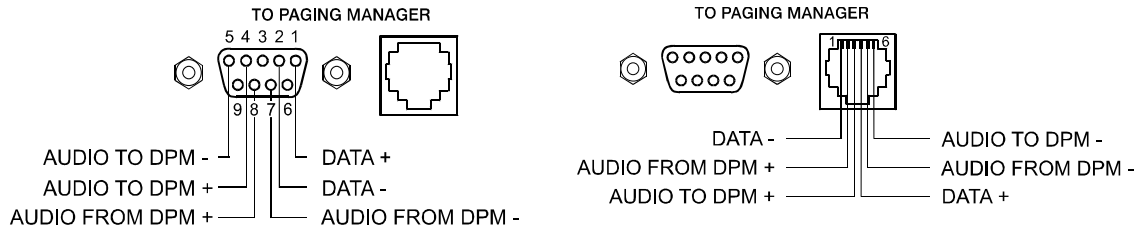

TO PAGING MANAGER connector's pin-assignment

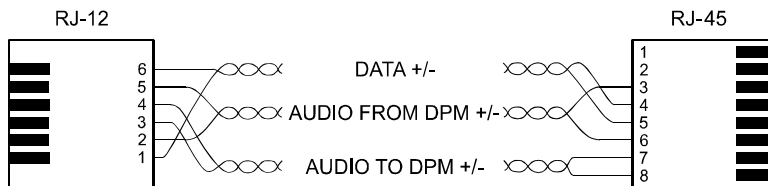

Interface cable RJ-12 / RJ-45

4.2 Connecting Phone Lines or a Telephone set

Two phone connectors are located on the rear panel of the DTI 2000. Connect the PHONE LINE socket with the telephone wall outlet. The LOOP THRU socket provides a connection facility for an optional telephone set.

NOTE: The LOOP THRU signal is disconnected whenever the DTI 2000 picks up a phone call via the PHONE LINE socket.

4.3 Power Supply

Insert the supplied power supply unit's round plug into the POWER SUPPLY socket on the rear panel of the DTI 2000. Turn the plug's safety lock clockwise to establish a securely locked connection. Afterwards, connect the supplied mains cord to the power supply unit before inserting the mains plug into the mains wall outlet. The DTI 2000 is immediately operational upon establishing accurate connection.

5. Adjusting the Audio Level

Adjusting the level of the audio signal that is transmitted to the DPM 4000 System Manager is possible via the LEVEL TO PAGING MANAGER trimmer. Doing so, use a small, flat screwdriver to first set the trimmer to its centre position. Call the DTI 2000 and speak with a normal voice into the receiver while adjusting the audio signal level for best transmission quality. The level meter should not indicate any signals in the red area.

The TO TELEPHONE indicator and the corresponding control are not currently used.

6. Country settings

Different countries and regions have different telephone standards, which may differ in e.g. signal level and dial tones. The DTI 2000 can be and should be configured to meet those individual requirements. Not doing so can result in faulty operation of the DTI 2000.

Generally, the DTI 2000 is factory pre-set prior to shipping. In case of problems, please contact the nearest service-centre or the technical support.

Operating the DTI 2000

First, make sure that the DTI 2000 has been correctly installed and connected, as described before. Be sure to check the address and DIP-switch settings.

The DTI 2000 has a Default Configuration, which suits most standard applications. Custom configuration of the DTI 2000 is possible using the PC Designer Software, which is explained in detail in the chapter "Configuring the DTI 2000".

DTI 2000 Default Configuration:

DTI 2000 Parameters	Default Configuration	Remarks
NAME	DTI-2000	Default Name
COMP	OFF	No meaning in the DTI 2000
BUZZER	OFF	No meaning in the DTI 2000
PRECHIME	OFF	No meaning in the DTI 2000
GERMAN	OFF	No meaning in the DTI 2000
DOSCHAR	OFF	No meaning in the DTI 2000
PTTPRIO	INT	No meaning in the DTI 2000
EXT	4350	No meaning in the DTI 2000
PASSW	111,2222	Level 1 / Level 2 passwords
GROUP0	NONE	No groups programmed
...	...	
GROUP20	NONE	
KEY1	SELECT 1	Call number table: No. 1 (01) = Zone 1 No. 2 (02) = Zone2
KEY2	SELECT 2	
...	...	
...
KEY99	SELECT 99	No .99 = Zone 99
KEY100	SELECT 100	No. 0 (00) = Zone 100
KEY101 ... KEY107	DISABLED	No meaning in the DTI 2000
KEY108	TALK,255,0,20	Talk in actual selection with priority 2
KEY109 ... KEY112	DISABLED	No meaning in the DTI 2000

The DTI 2000 decodes all DTMF dial tones as well as signal tones for the recognition of incoming phone calls, pressed keys and determination whether a connection has been dropped or if the calling party hung up. Each one or two-digit number between 0 (00) and 99 represents an individual function, which is assigned in a calling numbers table (either in the Default Configuration or via user configuration). Three or four-digit numbers are used for entering passwords. The asterisk (*) and hash mark (#) keys offer special functions; e.g. as separator, for clearing faulty entries (Clear), as talk button, or to drop a connection.

1. Telephone call to the DTI 2000

Simply dial the number of the telephone line to which the DTI 2000 is connected. You are presented either with a ring signal when the line is not busy, or otherwise with a busy signal when the line is already busy. After the specified ring count (refer to DIP-switch S202) the DTI 2000

accepts the call and establishes a connection. First, you will hear a short noise (DTI 2000 line test) followed by different tone signals, which indicate that the DTI 2000 expects further entries.

2. Password Entry

The DTI 2000 answers an incoming phone call with different tone signals, depending on its actual status. When not password-protected, a single tone signal indicates that the DTI 2000 is ready to accept a function command (via entering a one or two-digit function number). If protected by a password, the appliance answers incoming calls with a two-tone signal. Entering the password for the desired access level is necessary. To enter access level 1 you have to enter a three-digit password, for entering access level 2 a four-digit password is needed. While level 1 only provides access to zone and group selection plus launching announcements via the * key, level 2 allows accessing all functions (announcements, text message playback, macros, stop, etc.). After entering the correct password, the DTI 2000 acknowledges a request with a single tone signal. The DTI 2000 sends a two-tone signal when entering the wrong password. After entering the incorrect password three times in a row the DTI 2000 drops the connection.

3. Zone / Group Selection and Announcements

Once the DTI 2000 is ready to accept a command (indicated by a single tone signal) and access level 1 (or 2) has been activated, selecting a single or several zones, groups or the ALL-group and then making an announcement in the selected areas is possible. Selecting a single zone, group or ALL is possible through entering the one or two-digit code that represents the according selection function in the call number table. Selecting further zones / groups is possible by using the hash mark key (#) as a separator before entering the next number, and so on. Numbers not representing a selection or clear-function are ignored. Announcements are initiated via the asterisk key (*). The DTI 2000 indicates with a single tone signal that a selection has been made and that you can start making your announcement. A “Low Busy” signal (two-tone sequence – tones with different key) indicates that one or several low priority zones are busy. It is your decision whether you want to wait (enter #), or to interrupt the current announcement (enter * once again). A “High Busy” signal (rapid, high-pitch sequence of tone signals) indicates that one or several high priority zones are busy. Once the announcement is finished, you can enter an announcement end mark through using the hash mark key (#). The connection is not dropped, which enables you to select new zones or groups for making further announcements. Pressing the asterisk key after an announcement is finished drops the connection – the DTI 2000 “hangs up”.

4. Direct Call

The DTI 2000 allows making announcements in permanently pre-selected zones or groups (Direct Call). This function can only be accessed from access level 2. No other number selection is accepted if the selected one or two-digit number represents a talk function. Press the asterisk key (*) to launch an announcement. The DTI 2000 acknowledges this request with a single tone signal, indicating that it is operational and ready to accept your announcement. The DTI 2000 outputs a “High Busy” signal when one or several high priority zones are busy. After the announcement is finished, pressing the hash mark key (#) allows selecting other functions. Using the asterisk key (*) drops the connection.

5. Text Playback

The DTI 2000 offers the ability to playback pre-recorded text messages in permanently pre-selected zones. This function can only be accessed from access level 2. No other number selection is accepted if the selected one or two-digit number represents a text message function. Press the asterisk key (*) to launch text message playback. The DTI 2000 acknowledges this request with a single tone signal, indicating that it is operational and ready to accept desired function command.

The DTI 2000 outputs a “High Busy” signal when one or several high priority zones are busy. A tone-sequence indicates that a text message is being played back. Text message playback normally stops automatically but manually stopping the function is possible as well by entering the STOP-function number code (default setting = 0 respectively 00).

6. Macros

The DTI 2000 allows launching macros that are programmed in the DPM 4000 System Manager, thus providing access to special functions. For example: switching relays, starting and stopping signals, entering parameters, launching test sequences, and many others. The macro function can only be accessed from access level 2. No other number selection is accepted if the selected one or two-digit number represents a macro function. Pressing the asterisk key (*) launches a macro. The DTI 2000 acknowledges this request with a single tone signal, indicating that it is operational and ready to accept desired macro command. It sends a two-tone signal, when entering an incorrect command or if there is any other problem.

7. Cancelling a Function (Break)

Cancelling an announcement is possible using the hash mark key (#) (Break). The current zone selection is cancelled as well, while the connection to the DTI 2000 is not interrupted. The appliance acknowledges the request with a single tone signal and it is ready for new entries (a new zone selection, launching text message playback, triggering macros).

The hash mark key (#) can also be used to clear erroneously made entries. Using the hash mark key (#) directly after selecting a text, announcement, macro or stop function prohibits the function from being executed, but erases it instead. The DTI 2000 is ready for new entries.

8. Hang Up / Cancelling a Connection

Using the asterisk key (*) directly after making an announcement or pressing the hash mark key (#) forces the DTI 2000 to drop the connection and “hang up”. The DTI 2000 also interrupts the connection when the calling party hangs up. However, in that case, a few busy tone signals are output via the PA-system, which can be rather disturbing. Therefore, dropping the connection through the use of the asterisk key (*) is always preferable.

The DTI 2000 can also be configured to automatically drop a connection after a definable period of time. This is especially useful to prevent the PA-system from being blocked by a telephone announcement over longer periods or that it is constantly blocked because of malfunction or faulty connections. The period of time after which the DTI 2000 automatically drops a connection can be set in a range between 20 seconds and 10 minutes via the internal DIP-switch S203.

Configuring the DTI 2000

The PC Designer software allows custom configuration for the DTI 2000 to match any specific application. The programming procedure is equivalent to configuring a paging console. Programming a paging console’s function keys relates to the programming of a call number table for the DTI 2000. This table holds the assigned functions of up to 100 one or two-digit numbers (0 to 99). The buttons 1 to 99 on a console correspond to the call numbers and the table entries 1 to 99. The 100-key represents the call number or table entry 0 (respectively 00) and, as standard, another entry in the table is reserved for the talk function, which can be activated from a telephone set using the asterisk key (*). Using a DPC 4550 + DPC 4350 paging console in the PC Designer software for configuring the DTI

2000 is recommended, because this is the only way to gain access to the total amount of 100 call numbers (accordingly to 100 paging console keys).

Connect a DPC 4550 + DPC 4530 to the corresponding input at the DPM 4000 in the PC Designer Software, give it a meaningful name (e.g. telephone interface), and open the paging console dialog with a double-click on the paging console icon.

The paging console dialog allows assigning one of the following functions per each call number (0 ... 99) respectively for each entry in the table:

1. Disabled:

The call number #nn has no function.

2. Stop:

Stops the actually active audio signals (chime, text message playback, alarm) depending on the programmed stop function and priority.

3. Clear:

Clears the actual zone or group selection.

4. Select:

This function selects a zone, group (groups may include up to 100 zones) or all zones (collective call) for an announcement or text message playback.

5. Text:

This function starts text message playback in permanently pre-selected zones or groups or in the actual zone selection. Assigning priorities is possible.

6. Talk:

This function starts an announcement in selected zones or groups. It also provides the possibility to initiate a collective call in all zones. A permanently assigned zone or group as well as the actual zone selection can be defined as a target. Assigning priorities as well as programming a pre-chime signal is possible.

A special entry in the table is reserved for the standard talk function (corresponds to the talk button #108) , which can be activated from a telephone set using the asterisk key (*).

7. Macro:

This function starts a macro via its pre-defined macro number, which of course is only possible when a corresponding macro has been programmed in the DPM 4000.

A typical call number table might look like that:

Phone No. / Tone Dial Code	Function	Parameters	Priority	Remarks
1 (or 01)	SELECTION	Zone 1	0	Selects Zone 1
2 (or 02)	SELECTION	Zone 2	0	Selects Zone 2
3 (or 03)	SELECTION	Zone 5	0	Selects Zone 5
...
9 (or 09)	SELECTION	Group 2	0	Selects group 2
10	SELECTION	Group 5	0	Selects group 5
11	SELECTION	ALL groups	0	Selects all zones / groups
...
30	EMPTY	0	0	No function
...
49	EMPTY	0	0	No function
50	TEXT	Group 3, Text 2	4	Starts text No. 2 in group 3 with priority 4
...
59	TEXT	All groups, Text 3	7	Starts text No. 3 in all zones with priority 7

60	TALK	All groups	9	Starts an announcement in all zones with priority 9
...
70	MACRO	Nr. 15	0	Triggers macro No. 15
71	MACRO	Nr. 16	0	Triggers macro No. 16
...
99	CLEAR	0	0	Clears the actual zone / group selection
0 (or 00)	STOP	0	5	Stops audio signals with a lower priority than 5, which have been launched from the DTI 2000
*	TALK	Current selection	3	Starts an announcement in the current selected zone(s) with priority 3

Setting the DTI 2000's password codes is possible in the general paging console dialog. The two access levels have individual passwords. The default password settings are 111 (3-digit for user level 1) and 2222 (4-digit for expert level 2). Access level 1 only allows zone / group selection and making announcements through the use of the asterisk key (*) while the expert level 2 provides access to all functions (announcements, text message playback, macros, stop, etc.). Password-protection is inactive, so that anybody has access to the functions of the corresponding level, when entering "0" as a password.

In the DTI 2000, the attributes microphone compressor, tone signal and German date have no function and should be left at their default setting.

DTI 2000 Operation Example

Based on the configuration example of the previous chapter, the following commands can be carried out through the DTI 2000:

Function	Dial Numbers	Remarks
Connection number	0123 456789	Select the phone number of the DTI 2000 connection
Password	111 or 2222	Select the password for access level 1 or 2
Announcement in a single zone	1*	Selects zone 1, starts an announcement with priority 3
Announcement end	#	Stops an announcement while keeping the connection
Announcement in several zones / groups	2#3#9*	Selects zones 2, 5 and group 2, starts an announcement with priority 3
Hang up	*	Stops an announcement and drops the connection
Collective call	11*	Selects all zones, starts an announcement with priority 3
Clear incorrect selection	1#2#3#99	Selects zones 1, 2 and 5, clears the selection
Start text message playback	50*	Starts text No. 2 in group 3 with priority 4
Stops text message playback	0*	Stops text No. 2 (if launched from the DTI 2000)
Direct call	60*	Starts an announcement with 9 in all zones
Start macro	70*	Starts macro No. 15
Clear incorrect function entry	71#	Clears an erroneously made entry of macro No. 16 (does not start the macro)
Hang up	*	Stops an announcement and drops the connection

*** DTI 2000 tone signals (table)

Test Functions

The processor system automatically runs an initial self-test whenever the DTI 2000 is connected to the mains. During this procedure, first the red DROP LED should light. Afterwards, the orange TALK LED blinks for approximately 3 seconds. In case faulty operation is being recognized, the processor system stops and the DROP and TALK LEDs light. Otherwise the **DROP LED** is dimmed and only the red **DROP LED** lights as long as a telephone connection has not been established.

Pressing the SEIZE / DROP button on the front panel manually establishes a connection (pick up) or drops a connection (hang up). When the button is used to “take a call”, the green SEIZE LED should light and the red DROP LED should be dimmed. Pressing the key once again drops the connection and the red LED lights while the green LED is dimmed.

The orange TALK LED lights when the DTI 2000 is in announcement mode (i.e. when a telephone announcement in a single or several zones of the PA-system has been activated).

Specifications

Audio Output level	0 dBu ... +20dBu
Telephone Input Level	-30 dBu ... +6 dBu
S/N Ratio	> 60 dB (200 Hz ... 3.8 kHz)
Frequency Response	300 Hz ... 3.8 kHz (+0 / -6 dB)
Phone Line Connectors	2 x RJ-11 (Line / Loop Thru)
DPM 4000 Interface	RJ-12, DB-9 sockets
Power Supply	100 ... 240 V AC, 50 / 60 Hz
Temperature Range during Operation	0 °C ... 50 °C
Dimensions	208 x 44 x 203 mm (B x H x T), ½ 19“ / 1 HU
Weight	2.0 kg
Certifications	CE, UL, FCC

- Design and specifications are subject to changes without further notice -