

ELA-MODULE-SYSTEM

OWNER'S MANUAL

DEM 316 Batterie-MODULE 24 V / 38 Ah

DEM 317 Batterie-MODULE 24 V / 65 Ah

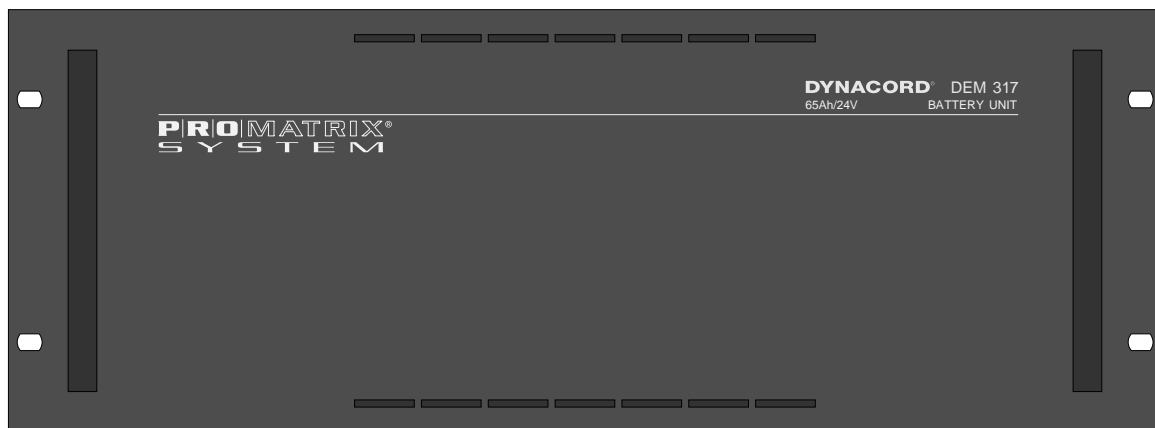

Features of the battery modules

- 19 " drawer-type chassis with 3 HU, 4 HU and 2x4 HU
- Rated voltage 24 V
- Energy storage completely maintenance-free, universal-location lead batteries with grid plates and fixed electrolyte, suitable for cycle operation, continuous battery power supply and trickle charge.
- Exhaustive discharge protection relay controlled by DEM 313 charger
- Charging input and battery outputs via AMP flat pin terminals 6.3 x 0.8 mm charging input and all battery outputs fused.
- Temperature tracking of charging voltage at standby charge depending on the battery temperature with integrated temperature sensor.
- Batteries with VdS-registration and UL recognition.
- The technical specifications comply with the requirements issued by the "Leistungsgemeinschaft Beschallungstechnik", pertaining to the professional association for audio and video technology in the ZVEI.

Table of Contents

Features of the battery modules	14
Table of Contents	15
Safety and Service Instructions	15
Rear Panel DEM 316	16
Rear Panel DEM 317A / DEM 317B	17
1. Emergency power supply of alarm apparatus	18
2. Commissioning the battery module	18
2.1 Battery module DEM 316/DEM 317	18
2.2 Battery module DEM 317 A and DEM 317 B	18
2.3 Fusing the inputs and outputs	18
2.4 BATTERY CONTROL connection	20
2.5 Connection for battery charging	21
3. Notes for the user	21
3.1 Use of the battery is to be avoided in the following locations	21
3.2 Regulations for battery use	21
3.3 Storage and additional charging	21
3.4 Transport	21
3.5 Battery life	22
3.6 Battery recycling	22
4. Registrations and Standards	22
5. Testing and inspecting alarm devices	22
6. Explanation of terms	23
7. Specifications Battery Modules DEM 316 / DEM 317	24
8. Block Diagram	25

IMPORTANT SAFETY INSTRUCTIONS

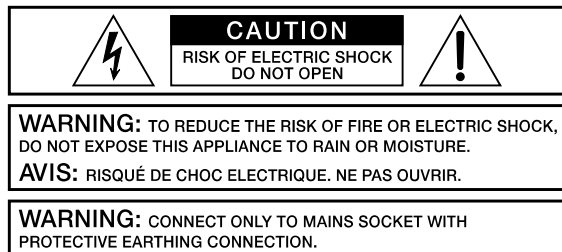

The lightning flash with arrowhead symbol, within an equilateral triangle is intended to alert the user to the presence of uninsulated "dangerous voltage" within the product's enclosure that may be of sufficient magnitude to constitute a risk of electric shock to persons.



The exclamation point within an equilateral triangle is intended to alert the user to the presence of important operating and maintenance (servicing) instructions in the literature accompanying the appliance.

1. Read these instructions.
2. Keep these instructions.
3. Heed all warnings.
4. Follow all instructions.
5. Do not use this apparatus near water.
6. Clean only with a dry cloth.
7. Do not block any ventilation openings. Install in accordance with the manufacture's instructions
8. Do not install near heat sources such as radiators, heat registers, stoves, or other apparatus (including amplifiers) that produce heat.
9. Do not defeat the safety purpose of the polarized or the grounding-type plug. A polarized plug has two blades with one wider than the other. A grounding type plug has two blades and a third grounding prong. The wide blade or the third prong are provided for your safety. If the provided plug does not fit into your outlet, consult an electrician for replacement of the obsolete outlet.
10. Protect the power cord from being walked on or pinched particularly at plugs, convenience receptacles, and the point where they exit from the apparatus.
11. Only use attachments/accessories specified by the manufacturer.
12. Unplug this apparatus during lightning storms or when unused for a long period of time.
13. Refer all servicing to qualified service personnel. Servicing is required when the apparatus has been damaged in any way, such as power-supply cord or plug is damaged, liquid has been spilled or objects have fallen into the apparatus, the apparatus has been exposed to rain or moisture, does not operate normally, or has been dropped.
14. Do not expose this apparatus to dripping or splashing and ensure that no objects filled with liquids, such as vases, are placed on the apparatus.
15. To completely disconnect this equipment from the AC Mains, disconnect the power plug from the AC receptacle.
16. The mains plug of the power supply cord shall remain readily operable.

IMPORTANT SERVICE INSTRUCTIONS

CAUTION: These servicing instructions are for use by qualified personnel only. To reduce the risk of electric shock, do not perform any servicing other than that contained in the Operating Instructions unless you are qualified to do so. Refer all servicing to qualified service personnel.

1. Security regulations as stated in the EN 60065 (VDE 0860 / IEC 65) and the CSA E65 - 94 have to be obeyed when servicing the appliance.
2. Use of a mains separator transformer is mandatory during maintenance while the appliance is opened, needs to be operated and is connected to the mains
3. Switch off the power before retrofitting any extensions, changing the mains voltage or the output voltage.
4. The minimum distance between parts carrying mains voltage and any accessible metal piece (metal enclosure), respectively between the mains poles has to be 3 mm and needs to be minded at all times.
The minimum distance between parts carrying mains voltage and any switches or breakers that are not connected to the mains (secondary parts) has to be 6 mm and needs to be minded at all times.
5. Replacing special components that are marked in the circuit diagram using the security symbol (Note) is only permissible when using original parts.
6. Altering the circuitry without prior consent or advice is not legitimate.
7. Any work security regulations that are applicable at the location where the appliance is being serviced have to be strictly obeyed. This applies also to any regulations about the work place itself.
8. All instructions concerning the handling of MOS - circuits have to be observed.

Note:  SAFETY COMPONENT (HAS TO BE REPLACED WITH ORIGINAL PART ONLY)

VORSICHT
 SPANNUNG ZWISCHEN BATTERIE
 UND GEHÄUSE BZW. GESTELL

100A IS THE MAXIMUM CURRENT
 AVAILABLE FROM THE EMERGENCY
 BATTERY AND MUST BE DISTRIBUTED
 BETWEEN THE OUTPUT TERMINALS.
 SEE OPERATING MANUAL.

WARNING
 SHOCK HAZARD. DO NOT OPEN. TO REDUCE THE RISK OF FIRE HAZARD
 AND ELECTRIC SHOCK DO NOT EXPOSE INSTRUMENT TO RAIN OR MOISTURE.
 AUIS
 RISQUE DE CHOC ELECTRIQUE. NE PAS OUVRIE.

CAUTION
 FOR CONTINUED PROTECTION AGAINST FIRE HAZARD REPLACE WITH
 SAME TYPE FUSE AS INDICATED.
 REMPLACER PAR UN FUSIBLE DE MEME TYPE COMME INDIQUE.
 NO USER SERVICEABLE PARTS INSIDE. REFER SERVICING TO QUALIFIED
 SERVICE PERSONNEL.

DYNACORD®

DEM 316

SER. NO.
 121331 -

MADE IN GERMANY

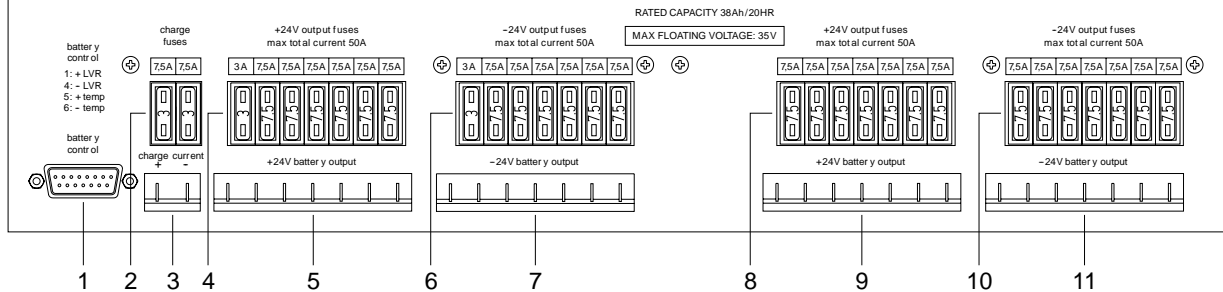

- 1 Connector BATTERY CONTROL
- 2 CHARGE FUSES
- 3 CHARGE CURRENT INPUT
- 4 +24V OUTPUT FUSES 1-7
- 5 +24V Outputs BATTERY OUTPUT 1-7
- 6 -24V OUTPUT FUSES 1-7
- 7 -24V Outputs BATTERY OUTPUT 1-7
- 8 +24V OUTPUT FUSES 8-14
- 9 +24V Outputs BATTERY OUTPUT 8-14
- 10 -24V OUTPUT FUSES 8-14
- 11 -24V Outputs BATTERY OUTPUT 8-14

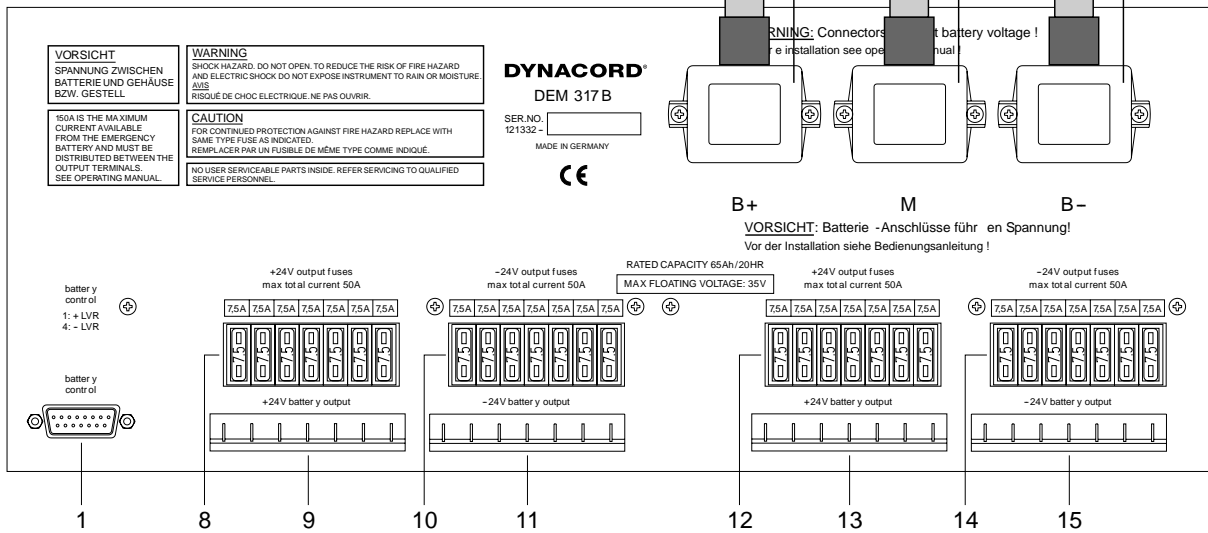
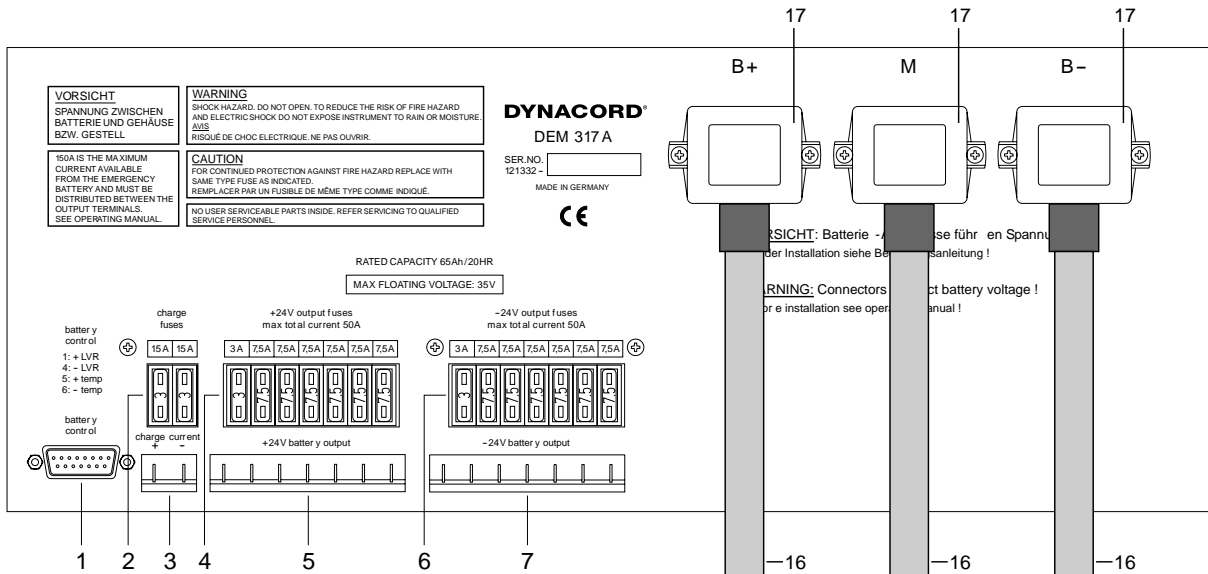

- 1 Connector BATTERY CONTROL
- 2 CHARGE FUSES
- 3 CHARGE CURRENT INPUT
- 4 +24V OUTPUT FUSES 1-7
- 5 +24V BATTERY OUTPUT 1-7
- 6 -24V OUTPUT FUSES 1-7
- 7 -24V BATTERY OUTPUT 1-7
- 8 +24V OUTPUT FUSES 8-14
- 9 +24V BATTERY OUTPUT 8-14
- 10 -24V OUTPUT FUSES 8-14
- 11 -24V BATTERY OUTPUT 8-14
- 12 +24V OUTPUT FUSES 15-21
- 13 +24V BATTERY OUTPUT 15-21
- 14 -24V OUTPUT FUSES 15-21
- 15 -24V BATTERY OUTPUT 15-21
- 16 BATTERY CONNECTION
- 17 BATTERY POLE WITH COVER

1. Emergency power supply of alarm devices

Alarm devices require 2 independent energy sources, both of which must be able to power the alarm device alone. One of the energy sources must be the general mains supply or a similar network in non-stop operation. The other must be part of the apparatus (e.g. a battery) or an equivalent network fused separately. If the mains power supply is interrupted, the second source of energy must guarantee constant non-stop operation automatically and without interruption. If the energy source belonging to the alarm device consists of a battery, the user must ensure that the batteries used are suitable for stationary and floating operation. The power supply for alarm devices must not be used to supply other apparatus or parts. However, electrical equipment which serves to pass on messages may also be powered by the said source. An automatic charging device is required to charge and maintain the battery. It must be able to charge a battery which is discharged to its discharge voltage up to 80% max. of its rated capacity within 24 hours. The battery capacity must be sufficient to guarantee the fixed alarm duration at the end of the stored energy time. When selecting new batteries, the user should make sure that their capacity is sufficient to compensate the capacity loss due to natural ageing of the batteries during the prescribed service life.

2. Commissioning the battery module

2.1 Battery module DEM 316/DEM 317

The following points must be observed:

- The battery may only be connected to the charging apparatus without load (i.e. all types of consumers must be disconnected) and when the mains is switched OFF.
- The battery must be charged directly after discharging. The battery must not be left uncharged. It becomes impossible to maintain a charge if the battery is left uncharged for any length of time.
- Please ensure that the temperature inside the rack is always within the admissible temperature range specified in the data sheet.

2.2 Battery module DEM 317 A and DEM 317 B

The following points must be observed:

- The insulated screw terminals on the rear side of the battery module DEM 317 are directly connected to the battery poles and are live.
- Before removing the insulating caps, all the connections of the battery modules DEM 317A and DEM 317B are to be disconnected.
- When connecting the cables, the insulating caps on the battery poles should never be removed at the same time because this could cause a short. After the cables have been connected they should be replaced immediately.
- The cables between the battery modules DEM 317A and DEM 317B connect the pole B+ with B+, M with M and B- with B-. When connecting the cables, the lock washer is to be mounted between the cable lug and the nut to secure the screw.

2.3 Fusing the inputs and outputs

The batteries have individually fused outputs for the load connections. Thus all plus and minus lines are protected against excess current and short. Different line cross-sections for consumers with low and high current can be connected to a battery at the same time, providing that the fuse values of their individual outputs are chosen accordingly. **The maximum value of the fuses must not, however, exceed 20 A.**

The total amount of the currents of all the output fuses in a fuse block must not exceed 50 A.

If the fuse values are changed, the current values printed on the units above the fuse switch are to be covered with the enclosed sticky labels. The fuse values for the appropriate plus and minus outputs must always be the same.

If any outputs are not used, the fuses are to be removed and and fuse values above the fuse switches are to be covered over with the enclosed blank sticky labels.

The output secured with 3 A is intended for connection of the control module DEM 207.

The cross-sections of the lines connected must be correctly dimensioned for the fuse value selected. Please note that lines laid in cable channels have a lower permissible current loading due to lower heat dissipation.

The following are guidelines for bundled lines

Number of lines	Reduction factor
2 to 5	0.8
6 to 15	0.7
16 to 30	0.5

Module type	Current consumption at Ebat = 24 V			Fuse value
	Standby	rated power -10dB	rated power	
DEM 287 power amp 125 W	10 mA	2.5 A	5.7 A	7.5 A
DEM 288 power amp 250 W	10 mA	3.5 A	10.6 A	10 A
DEM 289 power amp 400 W with NRS 90 144	10 mA	7.0 A	19.7 A	20 A
DPA 4120 power amp 200 W	2.5 mA	3.7 A	9.1 A	10 A
DPA 4140 power amp 400 W	2.5 mA	7.1 A	17.3 A	20 A
DPA 4410 power amp 4 x 100 W	2.5 mA	7.5 A	18.0 A	20 A
DPA 4411 power amp 4 x 100 W	2.5 mA	8.0 A	18.5 A	20 A

Table I Fuse values of the battery outputs for connection of power amplifiers

Table II shows the maximum currents which can be drawn from the batteries. These must not be exceeded. This gives the maximum number of power amplifiers which can be powered by the batteries.

max. number of power amplifiers*	Batterie -type	
	DEM 316 I max = 100 A	DEM 317 I max = 150 A
DEM 287 power amp 125 W	17	25
DEM 288 power amp 250 W	9	13
DEM 289 power amp 400 W	5	7
DPA 4120 power amp 200 W	11	16
DPA 4140 power amp 400 W	5	8
DPA 4410 power amp 4 x 100 W	5	8
DPA 4411 power amp 4 x 100 W	5	8

Table II Maximum currents and number of power amplifiers

* The number of power amplifiers which can be directly connected to the battery drawers can be lower than the values specified in Table II (see number of outputs, section 8, specifications). The values specified in the Table only refer to the connection of one amplifier type to one battery type. As long as the maximum current drawn is observed, however, various types of amplifier can be supplied by one type of battery.

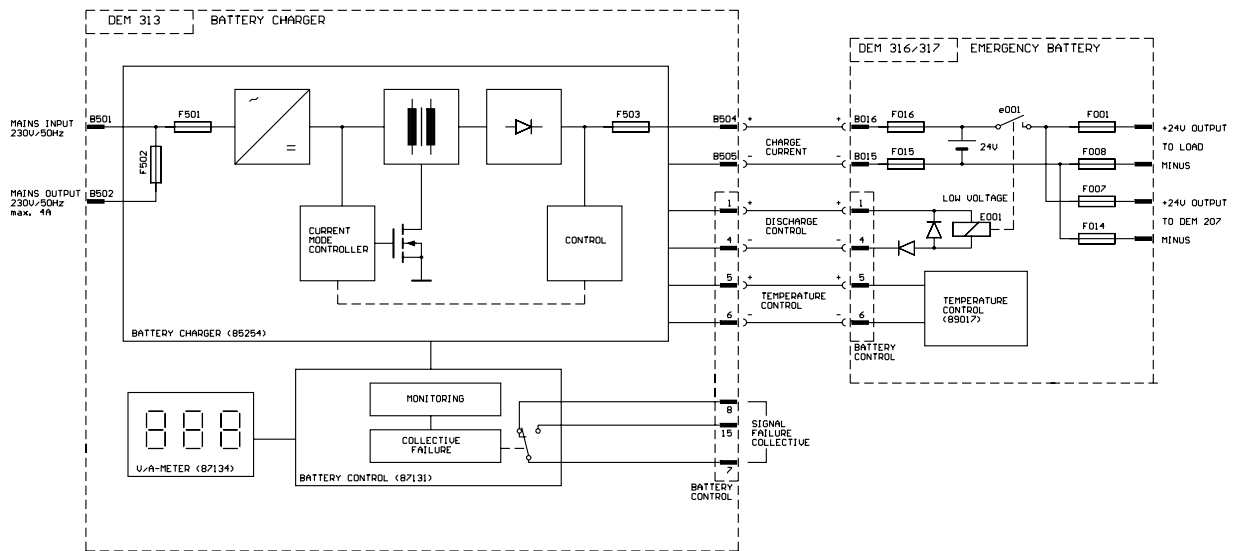

Circuit diagram of the battery connection to the charging device.

2.4. BATTERY CONTROL connection

The battery drawers are equipped with an exhaustive discharge protection which is controlled by the monitoring module in the charging device DEM 313. The monitoring circuit checks whether the battery's discharge voltage has been reached when the batteries are discharged. If the battery voltage is less than 19.5 V, measured at the battery poles, the consumers are disconnected from the battery and the battery is thus reliably protected from exhaustive discharge.

Note! If the 15-pole plug connector BATTERY CONTROL has not been correctly connected with the charging device, or if the battery voltage is lower than the discharge voltage, the battery outputs are not live

The connection of the temperature sensor for the temperature tracking of the battery voltage takes place via contact 5 (+temp) and contact 6 (-temp) of the 15-pole plug connector BATTERY CONTROL to the charging device DEM 313. If the connection is faulty, the temperature tracking does not work and the battery will not be charged. (Also see the operating instructions for the charging device).

In the case of the battery module DEM 317, the temperature sensor is located in the module DEM 317A.

2.5 Connection for battery charging

Connection of the charging device to the battery takes place via the flat pin connector CHARGE CURRENT. The plus pole of the charging device is to be connected to the plus pole of the battery, and the minus pole of the charging device is to be connected to the minus pole of the battery. (Please also see the operating instructions of the charging devices).

3. Notes for the user

3.1 Use of the battery is to be avoided in the following locations.

- areas exposed to direct sunlight
- areas with excessive radioactivity, infrared radiation or ultra-violet radiation
- areas with organic solvent vapours, dust, salt or corrosive gases
- areas with abnormal vibration.

3.2 Regulations for battery use

- Do not throw batteries into the fire. Do not place batteries in the proximity of fires.
- Do not short battery poles.
- Do not tamper with or open batteries.
- If the battery has been damaged and diluted sulphuric acid comes into contact with skin or clothing, rinse immediately with plenty of water. If diluted sulphuric acid gets into the eyes, consult a doctor immediately.
- Always re-charge a battery after discharging.
- Never use batteries with different capacities, different degree of discharge or a mixture of old and new batteries together. The manufacturing dates should be within one month of each other.
- Batteries should be stored at as low a temperature as possible. If batteries are stored at normal temperatures, additional charging is necessary once every six months.

3.3 Storage and additional charging

During storage the capacity is reduced due to self-discharge. The battery should be stored in a cool, dry place.

If the average monthly temperature is between 20°C and 30°C, one additional charging procedure is necessary every 8 months. If the average monthly temperature is less than 20°C, one additional charging procedure is necessary every 12 months.

If a stored battery is used, one charging procedure should always be carried out before use.

3.4 Transport

If the battery is transported, it should never be exposed to excessive jolting or knocks.

If a battery is connected to a device during transport, it must be secured well and the current circuit must be interrupted.

3.5 Battery service life

Generally speaking, the battery service life in standby parallel operation amounts to 3 - 5 years and approximately 260 cycles at 100% discharge depth or more in cyclic operation. The actual service life is reduced if the appropriate operating conditions are not maintained, (i.e. charging, discharging, working temperature and storage).

We recommend charging the battery at an ambient temperature of between 5°C and 35°C to minimize detrimental effects on its service life.

3.6 Battery recycling

The batteries are marked with a recycling symbol as illustrated below. At the end of their service life, the batteries should be returned to the manufacturer or supplier or taken to a special collection centre so that they can be recycled.

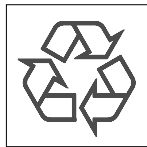

4. Registrations and Standards

- VdS registration

The batteries have been tested and recognized by the VdS (Verband der Sachversicherer) and comply with the following standards:

DIN 57 510 / VDE 0510 Akkumulatoren und Batterien, ortsfeste Batterien

DIN 43 534 "Wartungsfreie" verschlossene Akkumulatoren mit festgelegtem Elektrolyt

DIN 43 539 part 5 Prüfungen "wartungsfreie" verschlossene Akkumulatoren mit festgelegtem Elektrolyt

- UL approval

The batteries have received recognition from the Underwriters Laboratories Inc. and have been registered under the number MH 15705.

- IATA classification

The batteries have been cleared by the International Air Transport Association (IATA) for transport in aircrafts and have received the classification "leak-proof".

5. Testing and inspecting alarm devices

In order to guarantee that the alarm device is in working condition, qualified personnel must carry out inspections and servicing regularly.

Inspections must be carried out at least once every 3 months at approximately equal intervals to comply with DIN VDE 0833 part 1.

Servicing must be carried out at least once per year, in accordance with the manufacturer's instructions. The annual services may be linked with the quarterly inspections if so desired, meaning that all sections of the apparatus are inspected within one year.

For the battery of an alarm device this means:

quarterly tests and annual malfunction simulations of the operating duration with the consumers.

We recommend carrying out the battery capacity test in accordance with DIN 43 539 part 1, whereby the battery manufacturer's instructions are to be observed.

Please see section 3.2 for instructions on how to treat maintenance-free lead accus.

7. Explanation of terms:

- **Continuous battery power supply**
In this mode, the battery is constantly kept in full charge. It only gives off current if the DC source, supplied by the mains, fails.
- **Nominal capacity:**
The nominal capacity is the value in ampere-hours for a 20-hour even, uninterrupted discharge with I₂₀ up to the discharge voltage of 1.75 V/cell at a temperature of 22°C.
- **Capacity:**
The capacity of a battery is the amount of electricity which can be extracted under the conditions in question. It depends on the discharge current, the discharge voltage and the temperature.
- **Service life**
For batteries in alarm apparatus and emergency announcing systems, the end of a battery's service life is reached when the capacity is less than 80% of the rated capacity.
- **Stored energy time**
This is the time span between recognizing a failure in the mains supply and remedying this failure.
- **Alarm duration**
The alarm duration is the time during which the alarm signal is given off.
- **Emergency announcement duration**
This is the time during which announcements are made to clear the building or section of a building.

8. Specifications battery modules

Batterie-Module	DEM 316	DEM 317
Nominal voltage	24 V	24 V
Discharge voltage at 25°C (1)	19,5 V	19,5 V
Nominal capacity for 20 hr	38 Ah	65 Ah
Nominal discharge current I20	1.9 A	3.25 A
Capacity for 5 hr (2)	33 Ah	55 Ah
Capacity for 1 hr (3)	23 Ah	39 Ah
Capacity for 1 C (4)	20 Ah	33 Ah
Discharge current for 5 hr (2)	6.6 A	11 A
Discharge current for 1 hr (3)	23 A	39 A
Discharge current for 1 hr (4)	38 A	65 A
Max. discharge current	100 A	150 A
Standby current at mains failure	200 mA	300 mA
Number of outputs	14	21
Internal Resistance for 7.5 A Output	ca.50 mOhm	ca. 50 mOhm
End-of-charge voltage in standby operation at 20 °C (Continuous battery power supply)	27.3 V	27.3 V
Temperature adaption	-40 mV/°C	-40 mV/°C
Nominal charging current	4 A	4 A
Dimensions (W x D)	483 mm x 370 mm	
Height	178 mm	2x178 mm
Weight approx.	36.1 kg	30.0 kg (A) 30.5 kg (B)

(1) Discharge voltage at 25°C: 1.75 V/cell x 12 cells = 21.0 V

(2) Capacity at 5 hours discharge with discharge current for 5 hr

(3) Capacity at 1 hour discharge with discharge current for 1 hr

(4) Capacity at discharge with the current in A corresponding with the nominal capacity in Ah

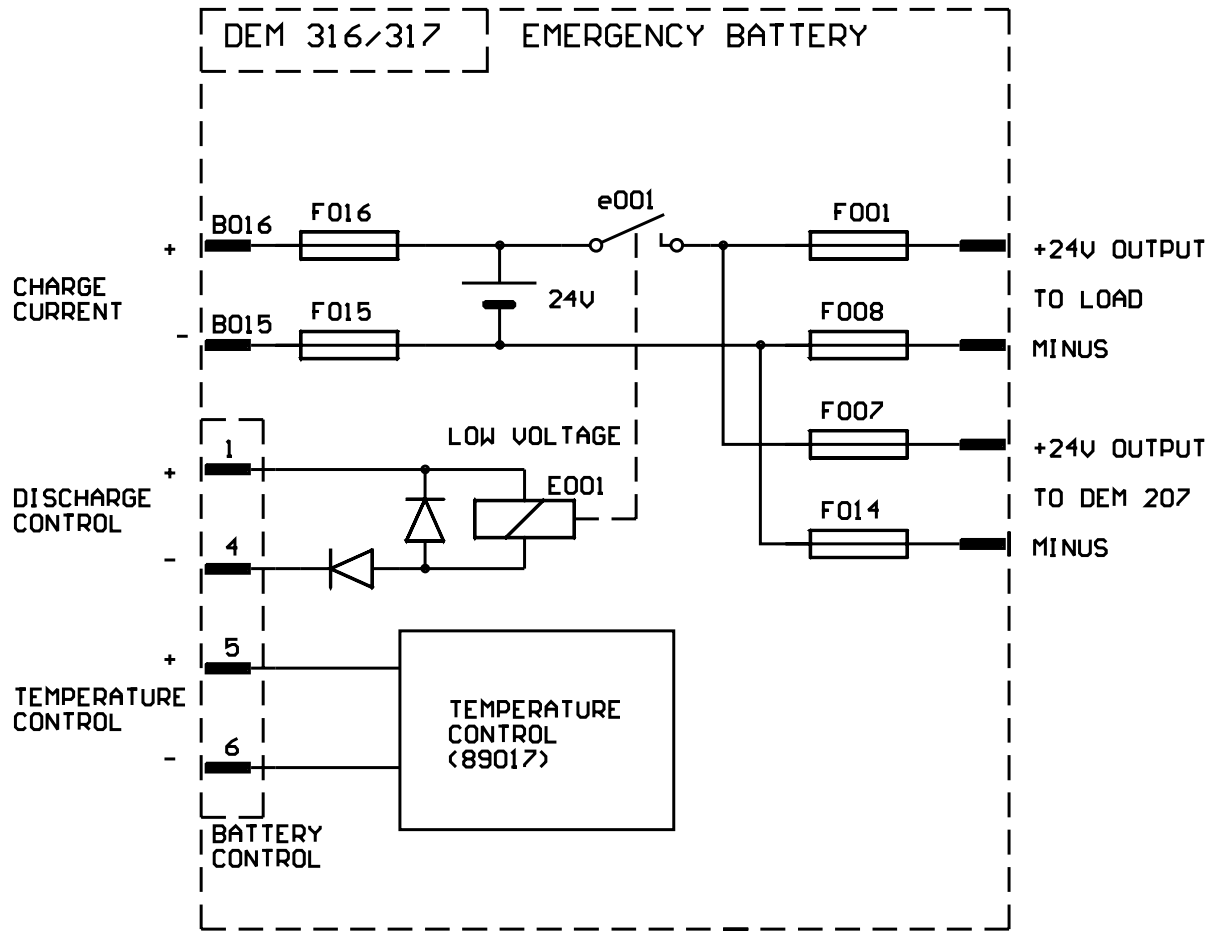

Block diagram

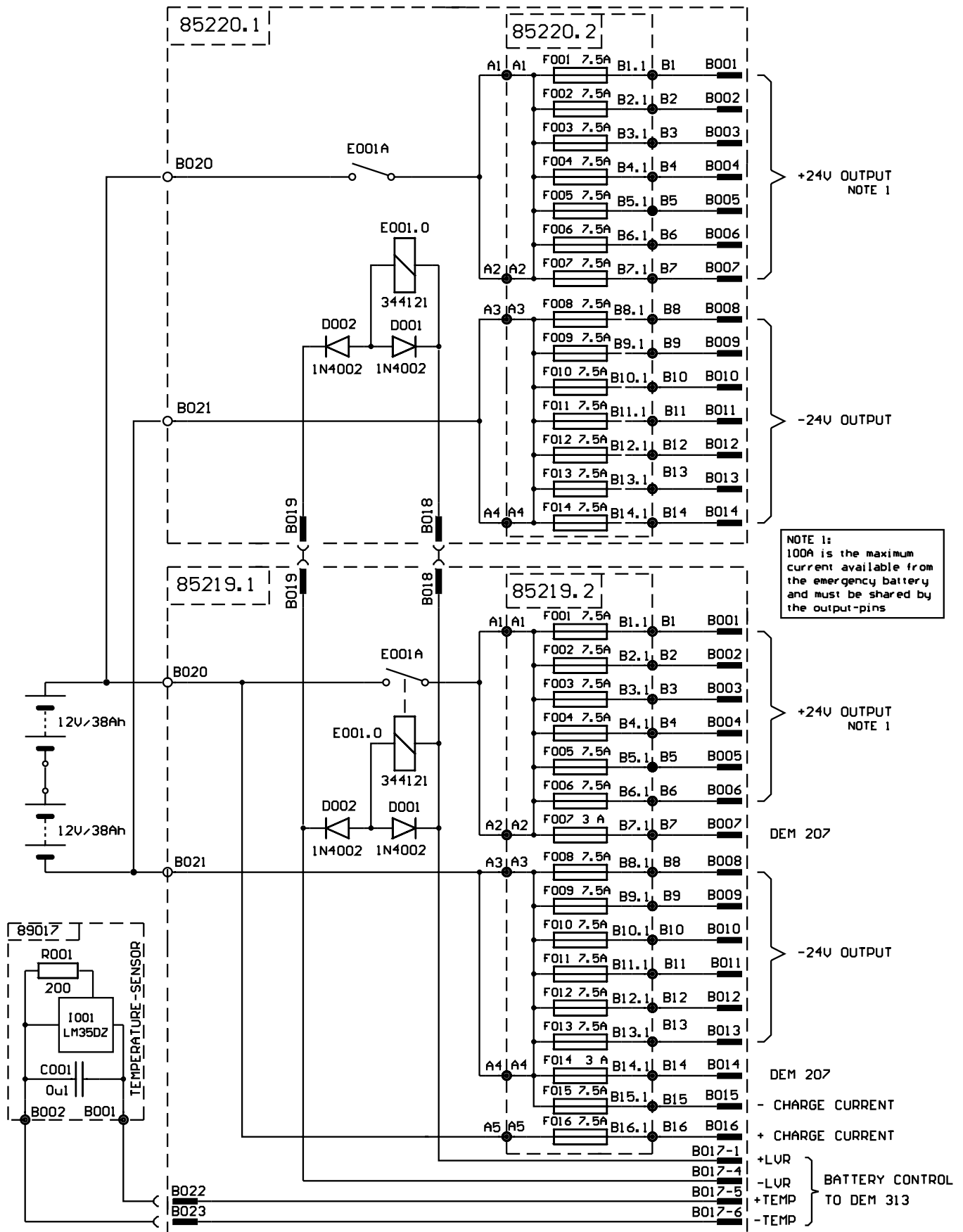

DEM 316

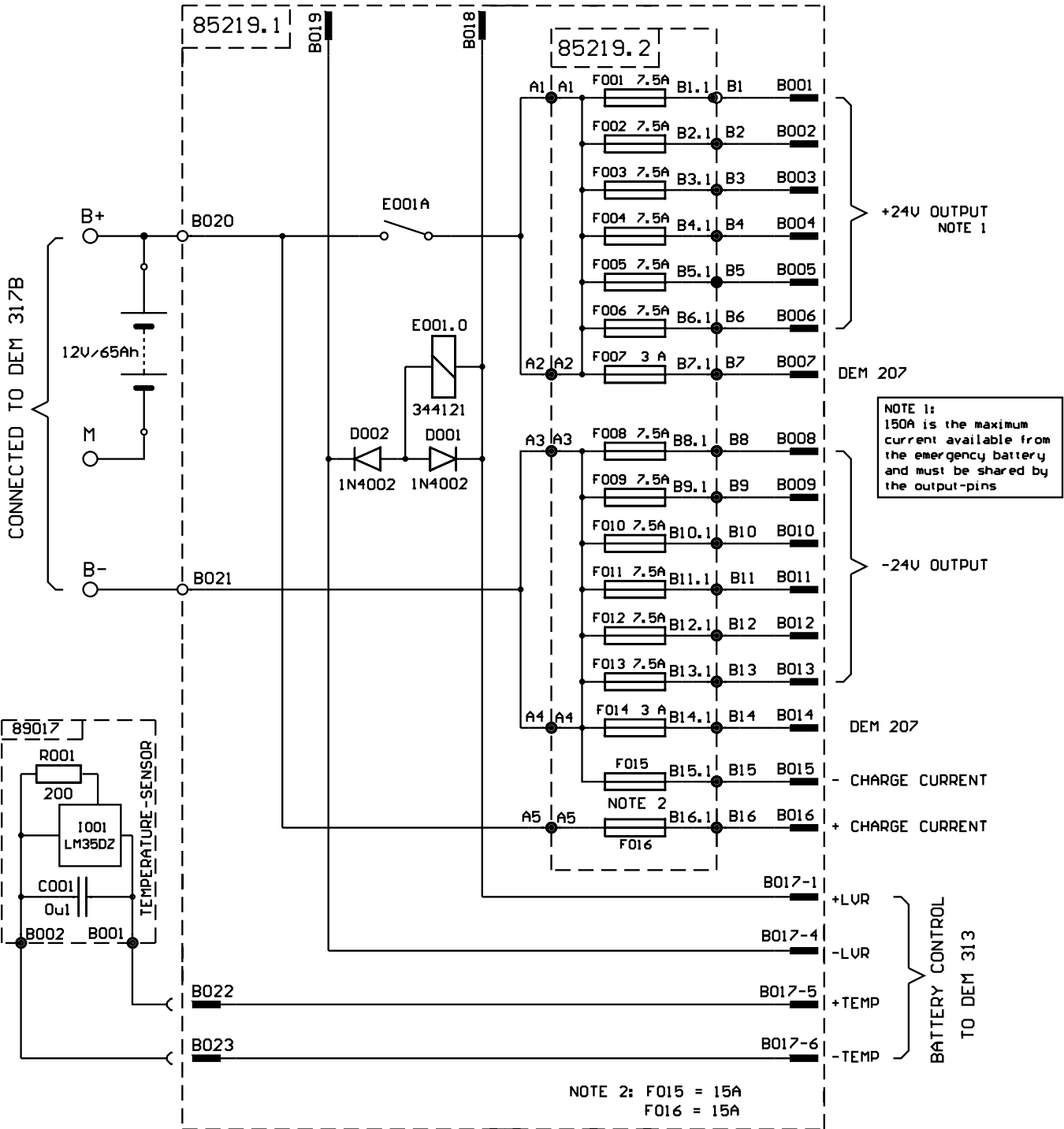

DEM 317A

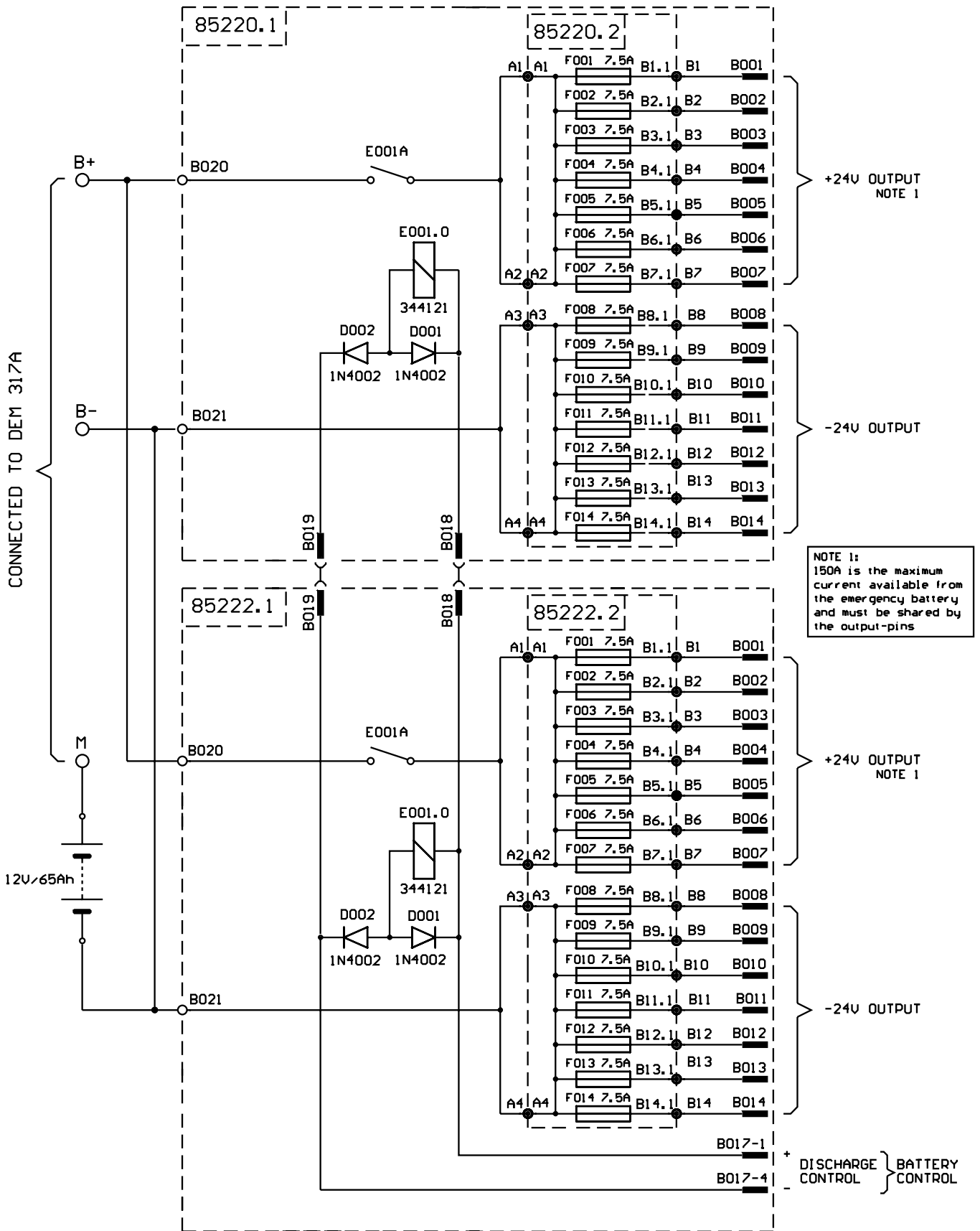

DEM 317B

Bosch Communications Systems

Americas—Headquarter Americas

Telex Communications, Inc.
12000 Portland Ave South,
Burnsville, MN 55337, USA
USA—Ph: 1-800-392-3497
Fax: 1-800-955-6831
Canada—Ph: 1-866-505-5551
Fax: 1-866-336-8467
Latin America—Ph: 1-952-887-5532
Fax: 1-952-736-4212

Europe, Africa & Middle-East

Headquarter EAME
EVI Audio GmbH
Hirschberger Ring 45, D-94315,
Straubing, Germany
Phone: +49 9421 706-0,
Fax: +49 9421 706-265

Asia & Pacific Rim—Headquarter Asia

Singapore: Telex Communications (SEA) Pte Ltd
38C Jalan Pemimpin
Singapore 577180
Tel: (65) 6319 0621
Fax: (65) 6319 0620

Japan: EVI Audio Japan Ltd.
5-3-8 Funabashi, Setagaya-Ku,
Tokyo, Japan 156-0055
Phone: +81 3-5316-5020,
Fax: +81 3-5316-5031

Hong Kong: Telex EVI Audio (HK) Ltd.
Unit 5, 1/F, Topsail Plaza
11 On Shum Street
Shek Mun, Shatin HK
Phone: +852 2351-3628,
Fax: +852 2351-3329

Bosch Communications Systems
Telex EVI Audio (Shanghai) Co., Ltd.
Room 3105-3109, No.1 Building, No. 218, Tian Mu West Road,
Shanghai, China.
Postal Code: 200070
Tel: 86 21-63172155
Fax: 86 21-63173023